



## **CHITETEZO MBAULA DRAFT GUIDELINES**

# **BRINGING THE BENEFITS OF IMPROVED COOK STOVES TO MORE PEOPLE**



**EDITOR**

Conor Fox

**CONTRIBUTORS**

Elizabeth Nyirenda

Cristel Chong

Christa Roth

Derrick Sanyahumbi

Miriam Phiri

**DESIGN AND LAYOUT**

Marcelo Lima

**ILLUSTRATIONS**

Hendi Mawera

**CLIOMA LTD.**

**PRIVATE BAG NUMBER 78 LILONGWE**

**INFO@CLIOMA.ORG**

**March 2012**



**CHITETEZO MBAULA DRAFT GUIDELINES****BRINGING THE BENEFITS OF IMPROVED COOK STOVES TO MORE PEOPLE****CONTENTS**

<b>Acknowledgements</b>	<b>4</b>
<b>Preface</b>	<b>5</b>
<b>Chapter 1 – How to make a Chitetezo Mbaula</b>	<b>6</b>
<b>Chapter 2 – How to sell a Chitetezo Mbaula</b>	<b>26</b>
<b>Chapter 3 – Stoves and health</b>	<b>38</b>
<b>Chapter 4 – Stoves and nutrition</b>	<b>48</b>
<b>Chapter 5 – Stoves and fuel</b>	<b>56</b>
<b>Chapter 6 – Stoves and gender</b>	<b>63</b>
<b>Chapter 7 – Stoves and climate change</b>	<b>68</b>
<b>Further information</b>	<b>74</b>

**CHITETEZO MBAULA GUIDELINES****BRINGING THE BENEFITS OF IMPROVED COOK STOVES TO MORE PEOPLE****ACKNOWLEDGEMENTS**

This is a draft version. People that provide relevant and constructive feedback will be acknowledged in this section of the first edition.

## PREFACE

For the benefits of improved cook stoves to be realised it is important that their dissemination is carried out with a high quality at all stages including selecting the most appropriate intervention including the type of stove, deciding on how the stoves are produced or procured, their promotion, their uptake and their sustained use.

There are many improved cook stoves on the market that can be promoted. The DISCOVER project specifically targets low-income rural households that predominantly use firewood as a fuel. The stove that has had most success to date in rural Malawi would seem to be a portable clay-fired stove that is called the “Chitetezo Mbaula” because of its affordability, accessibility and appropriateness. Importantly this stove has been designed and developed in Malawi and is made to meet local preferences for energy needs. These guidelines are specifically set out for Chitetezo Mbaula but can be relevant for other improved cook stoves. The guidelines are targeted at field facilitators, extension workers and project management to guide on how best to promote the production, sale and proper use of improved cook stoves.

The DISCOVER Project has set a very ambitious target of reaching 50,000 households with improved cook stoves or approximately 10,000 households in each of the five districts that the DISCOVER project is targeting. This will only be achievable if stove promotion is fully integrated into all other areas of the project such as crop diversification, village saving and loans, conservation agriculture, irrigation, disaster risk mitigation and climate change advocacy. This may not happen if integrating stoves into other areas of the project is not planned at a design phase and integrated into implementation at every stage.

These guidelines have been written before DISCOVER has begun implementation of the project and are based on experiences from other projects, programmes and initiatives in Malawi. There has already been a lot of effort to “raise the standard” on how to disseminate improved cook stoves. It is important that we build on the lessons learned to date and contribute to raising the standards. For this reason this version of guidelines is a draft or is provisional and can greatly benefit from the learning from you the user. We strongly encourage you to feed back to improve these guidelines so that more people can benefit from the sustained use of improved cook stoves. We look forward to your feedback by August 2012.

Senard Mwale  
Coordinator of Project Management Unit  
Discover  
Lilongwe, March 2012.

## CHITETEZO MBAULA DRAFT GUIDELINES

### CHAPTER ONE – HOW TO MAKE A CHITETEZO MBAULA

#### CONTENTS

<b>1.1 - Objectives .....</b>	<b>6</b>
<b>1.2 – Introduction.....</b>	<b>7</b>
<b>1.3 - Before you begin.....</b>	<b>8</b>
<b>1.4 - Do you have everything you need for a continued stove production? .....</b>	<b>10</b>
<b>1.5 - Preparing Clay .....</b>	<b>13</b>
<b>1.6 - How to mould a Chitetezo Mbaula .....</b>	<b>14</b>
<b>1.7 - Drying the Stoves.....</b>	<b>20</b>
<b>1.8 - Firing the Stove in a kiln .....</b>	<b>21</b>
<b>1.9 - Fuel-efficient Kiln .....</b>	<b>23</b>
<b>1.10 - Avoiding changes in design (design drift).....</b>	<b>25</b>

#### 1.1 - Objectives

This chapter describes the full production process of the Chitetezo Mbaula portable clay stove. Information is provided for each of the following stages:

- Sourcing and testing clay for producing the stoves,
- Preparing the clay for production,
- Moulding the stove, drying and firing the stove, and
- Conducting quality control during production.

This chapter is intended to help field facilitators and extension workers to promote, and help individuals and groups of entrepreneurs who are motivated and enthusiastic about becoming stoves producers and to ensure that such producers keep to required quality standards. The guidebook also uses lessons learned so far from the production and marketing of the Chitetezo Mbaula in Malawi.

## 1.2 – Introduction

Most of Malawi's cooking energy needs are met by fuels from trees like firewood and charcoal. As the country's population increases there is growing pressure on wood resources resulting in dwindling and degrading forests, higher prices and longer distances to find wood-fuel for domestic use.

Collecting fuel is hard work and takes up a lot of time and effort. It is usually the responsibility of women and children. For a woman that spends many hours every week walking to collect wood fuel, a reduction in the amount of wood she needs to prepare the daily food for her family will allow her to save valuable time and effort. In cases where firewood is purchased, it can lead to cash savings.

Improved stoves, such as the Chitetezo Mbaula, are being promoted in order to improve the quality of life for the people that rely on firewood as their main source of fuel. These stoves have improved design features appropriate to burn firewood efficiently. When used correctly, this leads to greatly reduced firewood requirements and amount of smoke in the kitchen. Due to its safer design with the fire contained in a fire-chamber, the Chitetezo Mbaula can also help to avoid accidental burns, thus the name 'protecting stove'. Chitetezo Mbaula is a simple conical pottery structure which is locally produced from local clay. It is designed to burn firewood, although it can also burn crop waste such as cobs and stalks from maize, pigeon pea, sorghum etc. It is not designed to burn charcoal.

The fuel is fed into the fire through an opening at the front of the stove. Chitetezo Mbaula is designed for one pot, but two or more stoves can be installed so that the cook can use more than one pot at a time. The stove's three strong pot rests can support a range of commonly used pots, with round and flat bottoms, from metal or clay.

Chitetezo Mbaula can be made by potters or trained community members using a metal mould to bring the clay into the correct shape with the correct dimensions. With the use of other simple purposely-designed tools it is possible to produce good quality stoves with standardised dimensions. These are important to ensure that the stoves can generate the benefits from fuel-efficiency. Changes in design should be avoided as they can compromise the stoves' performance.

The stoves are dried over several weeks, fired in a kiln and are then ready for use.



**Chitetezo Mbaula can assist to save firewood and reduce the efforts of wood collection.**

### 1.3 - Before you begin

#### Do you have a source of good clay?

Before you start thinking about a production of Chitetezo Mbaulas, you need to identify a good source of suitable clay available close to you. Traces of current or historic pottery activities in an area are normally a good indicator that there is suitable clay found nearby. The absence of pottery or brick-making activities in your area does not necessarily mean that there is no good clay to be found. The following can assist you to find an accessible clay in your area:

Find out information from people in the area. If there are no potters working now, ask older people and find out if there were any in the past. They will lead you to the clay sources.

If you do not succeed in finding clay that way, there are other places you can look, such as close to wells and termite mounds. Natural clay deposits are often found along river banks or *dambos*. On the other hand, if you know an area where the soil has large, deep cracks in the dry season, then this soil may have a high clay content. Also, look for places where the soil has been dug: if the surface left by the spade or hoe is shiny, this may indicate high clay content.

#### Remember!

All clay sources must be environmentally managed and monitored!

#### Do you have Pottery Skills?

Learning to make a Chitetezo Mbaula is quite easy for a skilled potter, but will require more attention and motivation for a person with no pottery experience. Even if no one in the community has pottery skills, it is still possible to learn how to produce a good quality Chitetezo Mbaula. It helps to learn the basic skills from skilled producers, who are already earning an income from making Chitetezo Mbaulas. With their experience acquired over many years of stove production, they can train other people on the entire production process starting with how to select and choose the right clay, prepare the clay, make good quality stoves, build a fuel-efficient kiln (burner), and fire the stoves in this kiln.



Elderly people may know where there are good sources of clay.



For the most successful stove production training, Village Based Trainers (VBTs) train others using “village-to-villager” communication and training. VBTs come from established production groups and are picked for their stove making ability, confidence, social skills and reliability.

### Clay testing

The only sure test to find out if the clay is suitable for stoves is to take it through the whole process of moulding, drying and firing. Then try using some stoves for cooking to see if they will last. Yet, there are some simple tests that you can do at this stage to get an indication whether the clay you identified can be used to make stoves:

First take a handful of clay, remove any twigs and stones and knead it into a smooth dough. Add some water if it is too dry. Try to roll it into a long, thin ‘sausage’ or ‘snake’ and coil this into a circle. If you can do this without the clay cracking, then it may be suitable for pottery.

Secondly, try to make a small thumb pot from the clay: Take a small handful of the soil and roll it into a ball, then push your thumb into the ball and squeeze the clay between your thumb and finger, gradually forming a small pot. If you are able to make a pot, you have found pottery clay that may be suitable for producing stoves.

Thirdly, measure the shrinkage of the clay. You need a ruler for that. Take a handful of clay and roll it into ‘sausages’ and cut 5 pieces of exactly 10 cm length. Measure this with a ruler. Dry the pieces for at least a week and fire them in the embers of a fire until they glow red and do not dissolve in water any longer. Measure the pieces again: If they are still at least 8,5 cm long, the overall shrinkage is less than 15% and the clay may be suitable for stove production as it is. If the pieces are considerably shorter than 8,5 cm you may need to add fine sand to mould good stoves. Try again adding more sand to the clay and repeat the test. Or ask skilled stove makers from other areas for assistance.

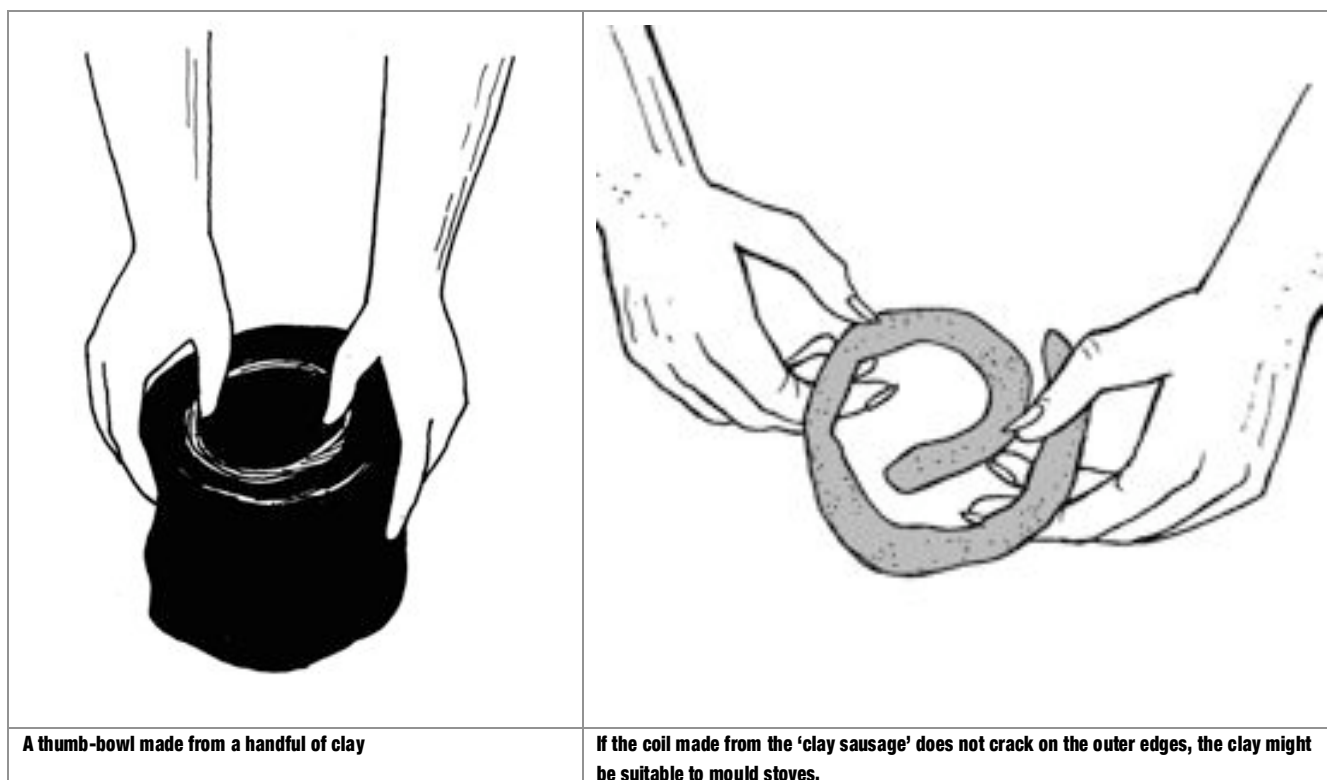

If you have found a good clay source you will need to check the following points:

- It should be accessible throughout (most times) of the year.
- It should be less than 3 km away from your intended production site. If it is further away, you should also calculate the cost and added effort of transporting it to your production site.
- You have to agree with the owner of the land or the local chief on the terms of extracting clay before you start. Agree with them whether you will be allowed to collect clay there and if and how much you have to pay for it.
- The clay extraction should not cause any environmental damages.
- Ideally a clay source should be large enough to last for at least a few years. Otherwise you will need to keep testing new sources.

## 1.4 - Do you have everything you need for a continued stove production?

You will need enough people to mould stoves for a continued production of stoves. Other than that you need:

### Consumable materials:

- Enough clay to produce a minimum of 100 stoves per month. Before the first production training there must be enough clay for 100 stoves to fill one kiln load for the first firing.
- A water source has to be close to your production site. Or you need drums to store water on site.
- You will need an adequate supply of firewood for firing the stoves in the kiln (approximately 1 cubic meter per firing).

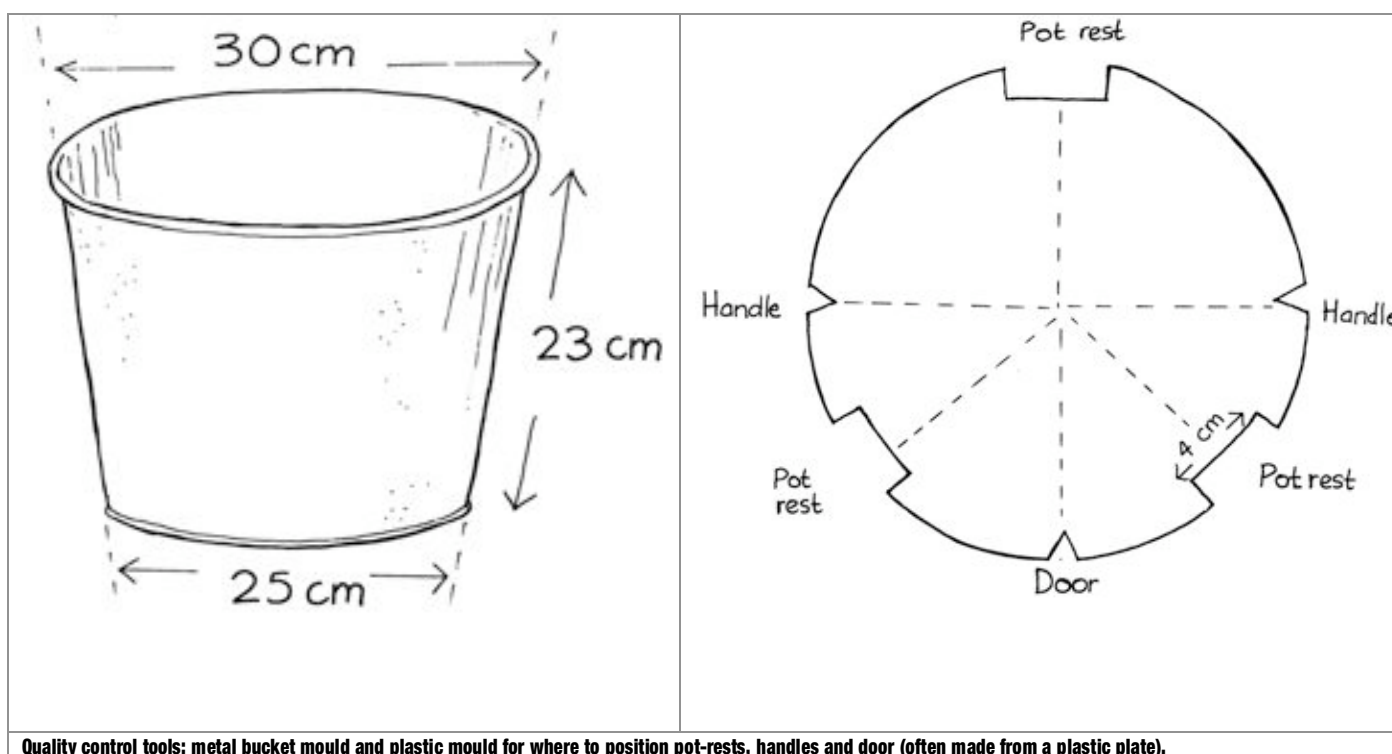

Quality control tools: metal bucket mould and plastic mould for where to position pot-rests, handles and door (often made from a plastic plate).

## Equipment and work space

- Clay pits need to be dug to accommodate the clay during two weeks of curing before use. The pits should be 50 cm deep and need to be lined with polyethene sheeting (e.g. black plastic) to keep the clay moist.
- The production site should be big enough to allow several people to work at the same time moulding stoves.
- The space should provide shade and have a flat surface area, so that the wet stoves don't take up an odd shape.
- The production site needs a sheltered space to slowly dry the freshly moulded stoves. It should provide protection from the elements (rain, sun and wind) and animals, which could destroy the wet stoves. If there is not enough floor space to accommodate at least one kiln load of stoves for 1 week of drying, shelves can be an option.
- After one week of drying the stoves will be hard enough to be piled up in piles up to 2-4 stoves. The stoves should be turned upside down to stand on the potrests to provide good ventilation of air inside the stove to assist drying. There needs to be enough well ventilated space to keep the stove piles drying up completely for 3-4 weeks.
- There should be a lockable space for the fired stoves and maybe for the production tools.
- Ideally, per individual stove producer there should be sack (to cover floor to avoid the clay to stick to the ground), one metal bucket mould, a hard plastic sheet (to line the bucket mould before putting the clay into the mould), a hard wire or bicycle spoke (to cut the door) and one complete set of quality control tools. These are tools from bamboo or wood, which are used for measuring all different parts of the stove during moulding to ensure standardised dimensions of the produced stoves.
- Pieces of plywood of 30x30 cm are recommended to be used as trays to carry freshly moulded stoves without damaging the shape of the wet stoves.
- Per production centre you will need at least one metal door mould, one concrete mould for the potrests and one plastic plate with a pattern that assists in a symmetrical layout of the stove features (door, handles, potrests).
- Per production centre one kiln is needed for the firing of the stoves. This needs to be built in a suitable place close to the production site. It needs a reasonable flat place of at a safe distance from trees and houses. The recommended model is the 'better bonfire kiln'.

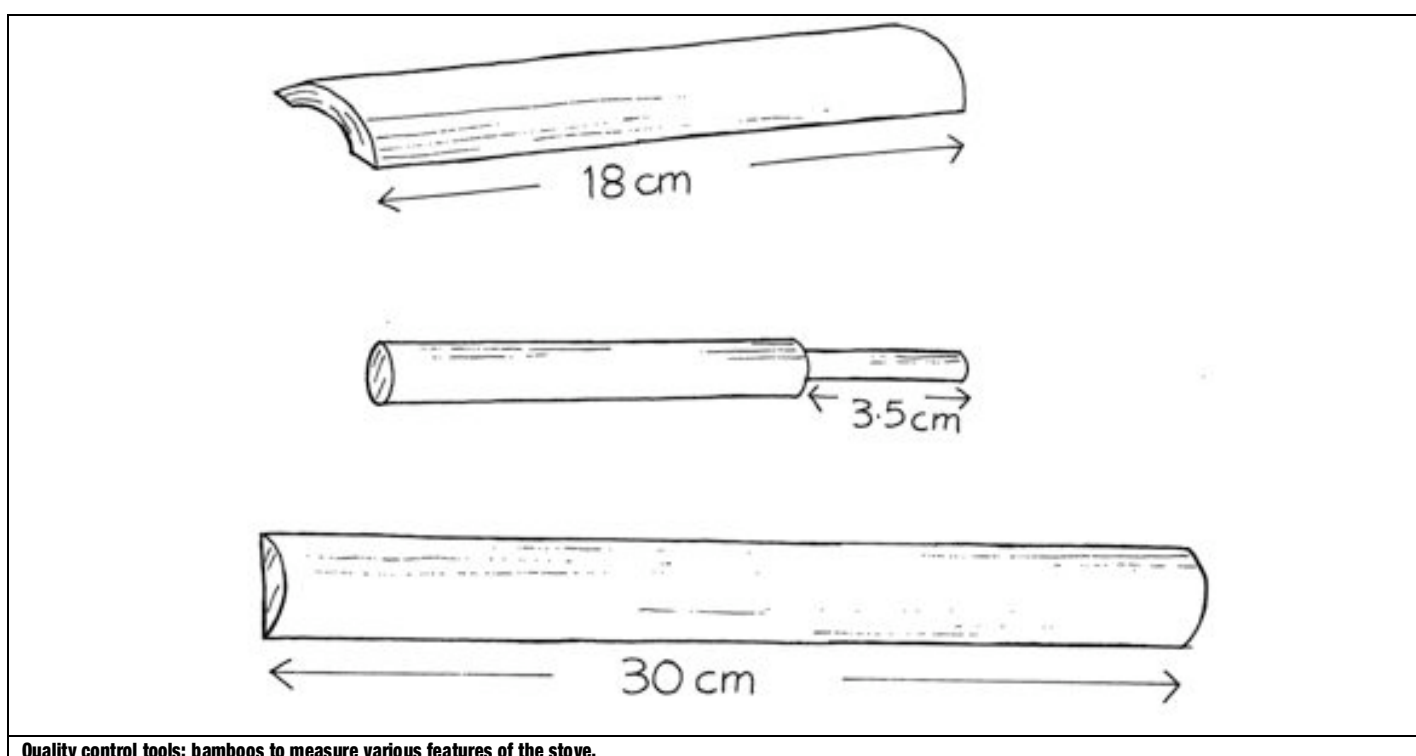

Quality control tools: bamboos to measure various features of the stove.

## Quality control can help to produce attractive and marketable stoves

Quality control is key to produce good quality stoves with standard dimensions. Quality control should be applied along the entire chain of production:

- Before moulding stoves the quality of the clay should be constantly monitored to prevent cracking of stoves.
- Each stove should be moulded to be the correct size and shape so that it will be efficient: The pot-rests should all be the same height and thickness. The door should be cut to the correct dimensions of the mould. The handles should be at the correct height and be easy to hold (no sharp edges or odd shape).
- Before letting stoves to dry, check that each stove looks attractive so that customers will want to buy it.
- Make sure each stove has a proper serial number and the initials of the producer so stoves can be tracked.
- Before firing check every stove for cracks and other imperfections. Discard cracked or odd-shaped stoves and recycle the clay. Once fired, you can not reuse the clay.
- After firing check each and every stove again and record the properly fired stoves (in groups this might be the secretary). Putting bad quality stoves on the market might spoil the reputation of the stoves.
- Each stove must be durable. It shouldn't break during transportation or when it is first used. Otherwise customers will be disappointed and complain.

**Apply quality control to find happy customers willing to pay a good price for your stove.**

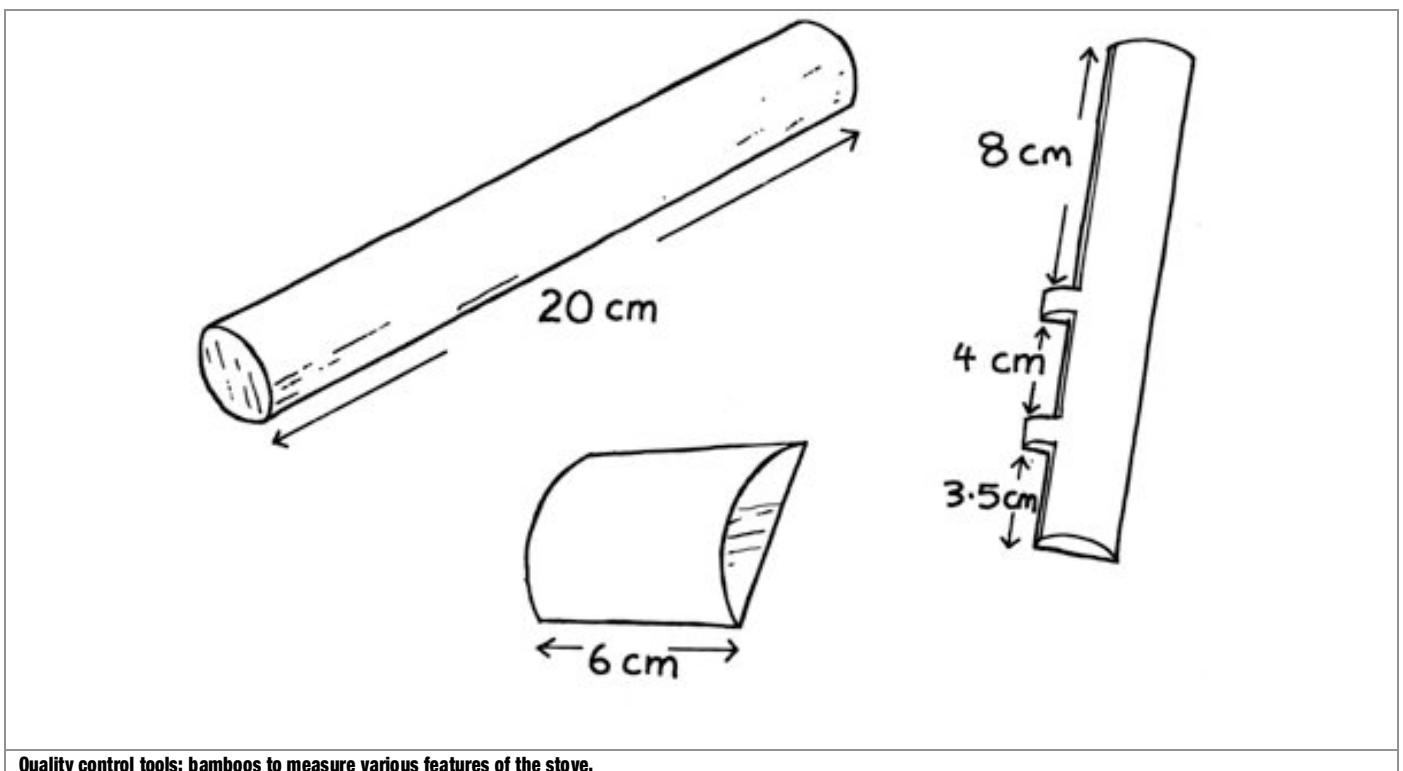

Quality control tools: bamboos to measure various features of the stove.

## 1.5 - Preparing Clay

The clay is dug out from the source, dry or wet, and then broken into pieces. If the clay is dry, add water carefully to form workable clay. If necessary, depending on the type of clay, the correct quantity of fine sieved sand can be added and mixed in well to provide enough stability for the stove. The moist clay is wrapped in polyethene (i.e. black plastic) and left to cure for 14 days in the clay pits. Every 3 days the clay is checked if it is still moist enough. If needed, add water and stir with a hoe to make a uniform dough until it is ready for moulding of stoves.

To mould the stoves, the clay is taken from the pit and placed on some sacks to prevent dirt from the ground to stick to the clay. Then big stones, roots, leaves, and other visible organic material are removed by hand from the clay. To detect all impurities like stones to be removed, trample on the clay with bare feet. The soles of your feet are sensitive and will detect stones easily while you mix the clay thoroughly into a smooth and homogeneous dough.

Proceed with your hands and process the clay with your fingers. The fingertips are even more sensitive than your feet. The aim is that no impurities and air bubbles are left in the clay that could make the clay burst when fired in the kiln.

### Important things to remember for clay preparation are:

- Before preparation, the clay must be cured (rested in the pits) enough for it to be workable and pliable (i.e. easily bent and flexible). Curing allows several important changes to take place in the clay structure.
- After preparation, the clay must have no air pockets, stones, lumps or waste materials in it, or the clay will burst in the fire. The clay mixture must be consistent. The clay must be very well mixed and form a homogeneous dough, ready to mould stoves.



**Trample on the clay with bare feet. The soles of your feet are sensitive and will detect stones easily while you mix the clay thoroughly into a smooth and homogeneous dough. Apply force with your heels to break hard lumps of the clay.**

## 1.6 - How to mould a Chitetezo Mbaula

Ingredients	Equipment	
Prepared clay	Bucket Moulds	Plastic 'paper' (polyethene sheet)
Water	Bamboo spatulas and quality control tools	Pot-rest mould
Ash	Plastic plates for pot-rest and door marking	Wire (spoke) and door cutting mould

### DAY 1: moulding the stove body with the bucket mould.

Move the soil from the pits to the working place where you are going to mould the stove. Ensure once more, that you remove stones and all unnecessary things by hand. Your clay should be very smooth now and ready to mould. Take care not to spoil the clay with material from the ground, so always keep the clay on a clean sack. In the end pile up the clay in a small anthill-like mound (see drawing below), ready to be put in a bucket mould.

- Line the inside of the bucket mould with a hard plastic sheet like that from a bale of sugar. The plastic sheet is sprinkled with some water so that the clay (stove-body) can be easily removed later without sticking to the mould.
- Place the lined mould on a clean and dry sack resting on flat surface, or if available, use a piece of plywood, so that you will be able to turn the bucket mould on the ground without the clay touching the ground surface,
- Pick up the clay-pile and throw it with the pointed end first into the bucket mould. Use force to throw, so that the clay takes the shape of the mould well. Check that the clay is centered in the mould and the mould is flat on the ground.
- Use your fist to make a hole in the center of the clay in the mould. Take the 18-cm quality control tool to widen and deepen this hole until it has the required height of 20 cm. Check this height with the 20 cm quality control tool.



Clay piles to put into the bucket mould.

- Use the 30 cm tool to flatten the stove on the top to be level with the upper edge of the bucket mould.
- Use the 3.5cm end of the 'kamano' (teethed) tool to probe the thickness of the stove. It should be uniform all around.
- Where it is thicker (where you see the mark of the tool on the clay on the top edge) use the 18 or 30 cm tool to remove clay until you reach the required thickness all around. Probe the thickness of the other places of the wall using the 'pencil' shaped tool. Keep removing (or adding) clay until all the walls are of uniform thickness. Do the same with the bottom of the stove so that it is not too thick.
- Smoothen the inside of the stove with the 18 cm tool and a little water. Be careful not use too much water and soak the stove, as it will destabilise the clay when it is too wet.
- Measure the height of the stove again with the 20 cm tool.
- Check again on the thickness of the stove walls.
- Place a sack, a piece of plastic sheet or plywood on a flat surface in the area where the stove can be left to dry. The surface should be flat and even, or the structure will be 'stamped' into the wet clay.
- Pick the mould with both hands from the outside. Be careful not to squeeze the sides and alter the shape from round to oval. Then turn the mould over (upside) onto the sack, plastic or wood. Expect the stove to be heavy!
- Before removing the mould and the hard plastic check the bottom of the stove (which now is facing upwards) if it is smooth and level with the edges of the mould. If it is not, the stove later will wobble or lean to one side. Add some clay to level the bottom if necessary. Use the 30 cm tool to create a level bottom.
- Remove the mould (lift it up) and then carefully peel off the hard plastic starting from the ground upward. As the hard plastic sheet always leaves marks on the wet clay, add some clay to fill any gaps and smoothen the 'wrinkles'.
- After smoothing the outside of the stove and the bottom, then write your name (or your initials) and the date of the day of production on the stove while the clay is still wet. Use the spoke or a wire to write. Writing your name helps you to identify which is your stove and not mix it up with your friends stove.
- Wash the mould and your tools thoroughly when you finish moulding the last stove so that everything is completely clean and dry; ready for making the next stove.



**Handle each wet stove with great care. Avoid pushing it out of shape, because although it can be reshaped, it may crack later during drying or firing.**

## Day 2: Finish moulding the stove

- Leave the stove to dry for a day, to make the clay firmer. To avoid damaging the shape, do not move the stove until it is dry enough to cut the door and fit potrests and handles. If the weather is cool or wet, you may have to leave it to dry for two days. The stove must not get too dry before finishing, otherwise the potrests will not bond well and fall off.
- Once the stove is dry enough to keep its shape when handling it, turn it carefully the right way up (bottom down).
- Start smoothing the stove until it shines and verify again height and thickness of stove walls.

### Marking of features:

- Take the plastic plate and place it bottom down on the top of the stove. Transfer the marks on the plate onto the top edge of the stove to indicate the locations of the potrests, door and handles.
- Take the 'kamano' tool with the longer 8 cm-end pointing down and place it vertical where you have transferred the marks for the door and the handles. Press the bottom end of the 'kamano' lightly onto the stove body to leave a mark 8 cm below the upper edge of the stove body. Do this in all three locations and should have 3 marks.
- Place the template of the door against the stove so that the highest part of the mould points at the mark from the plate. The door should be in the middle between the handles and there should be not potrest above. Mark the outline of the door mould on the clay without yet cutting the door open as this might destabilise the stove. Cut the door last after fixing handles and potrests.

### Handles:

- Cut the holes for the handles: pierce the spoke through the stove wall at the mark for the handle. Then cut out a circle ca. 2 fingers wide underneath the mark. Remove the clay from the circle. Do this on both sides. The holes should be exactly opposite of each other and the door mark should be in the centre on the front.

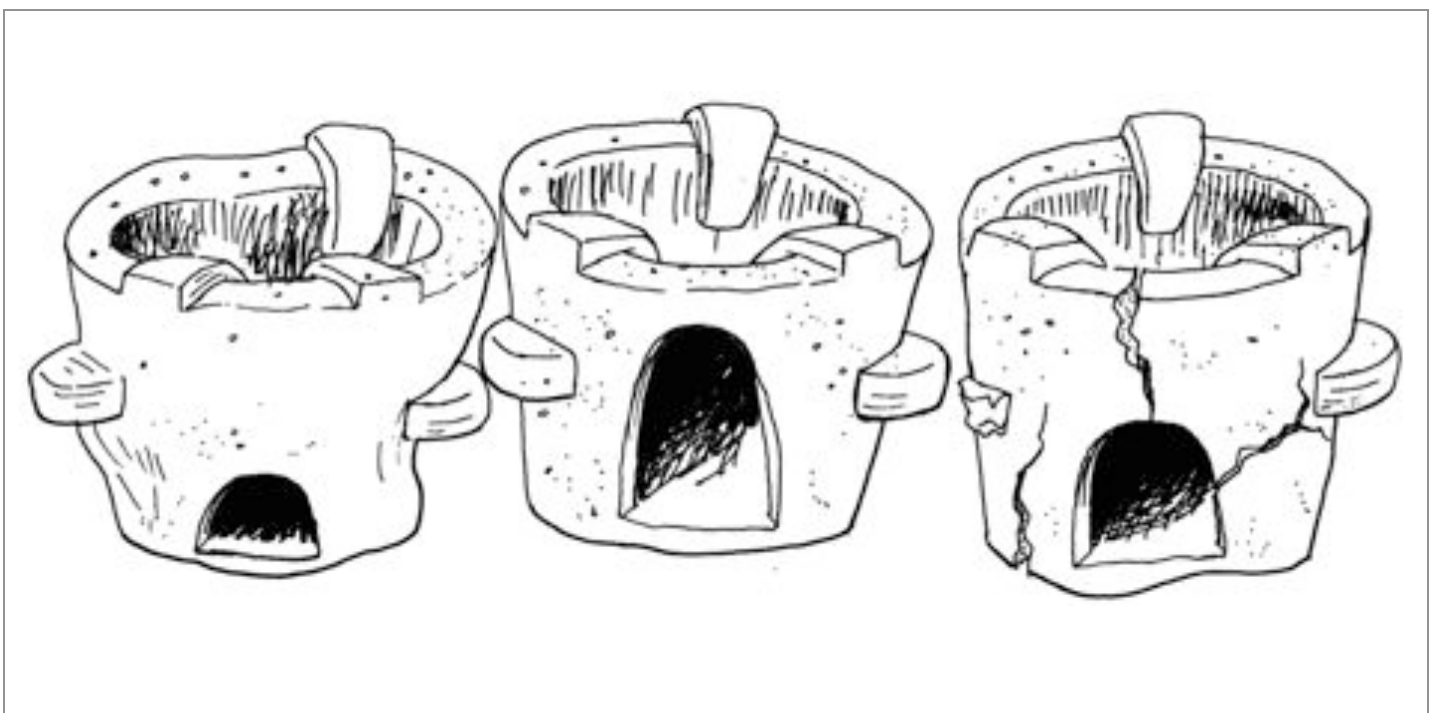

**Low quality stoves with cracks, bad finishing, odd shapes are unattractive. People are not prepared to buy them. Attractive stoves are easier to sell at a good price. Good quality stoves will last longer and keep customers satisfied.**



- Make two 'sausages' ca. 3 fingers thick from fresh clay and stick one by one in the holes. As the sausage is larger than the hole, force one end in: it should go right through the hole to anchor the handle in the stove wall and provide stability for the handle. Make sure no air gaps remain between the stove wall and the sausage. The other end of the sausage should be smoothed to both sides of the hole to make the actual handle.
- Check the length with the short end of the 'kamano'. The handle should be protruding by 3.5 cm.
- Join the clay of the handle well with the clay from the stove body, so that the handle will not break off.
- Smoothen the surface so that there are no sharp edges that will make it uncomfortable to hold the handles. The shape of the handle should be flat and easy to grab to lift the stove up. Avoid a round shape like a knob as this might slip in the hands and the stove might turn over when lifted, which can be dangerous when it contains hot char that can fall on peoples' feet and cause burns.
- The handles should be not lower than 8 cm underneath the upper edge of the stove body, in order to prevent accidents: If the handles are lower, the stove will become top-heavy and is likely to turn over when lifted. This can cause severe burns which should be avoided.

#### Potrests:

- It is very important that the pot-rests are equally spaced to ensure that the cooking pot will sit stable on the stove.
- Prepare the pot-rest mould made from concrete: Line the mould with a small plastic sheet and sprinkle a small amount of water onto the plastic sheet.
- Make three large sausages ca. 3 fingers wide from the clay. Note that the clay must not be very wet.
- Press one clay sausage into the pot-rest mould, making sure that it completely fills the mould. Scrape off any excess clay with the bamboo tools to leave an even surface level with the edges of the mould.
- To remove it from the mould, pull the plastic sheet carefully up and place the clay shape in your hand. Be careful not to damage the shape. Peel off the plastic, then smoothen the surface of the potrest. Make two more pot-rests in the same way.

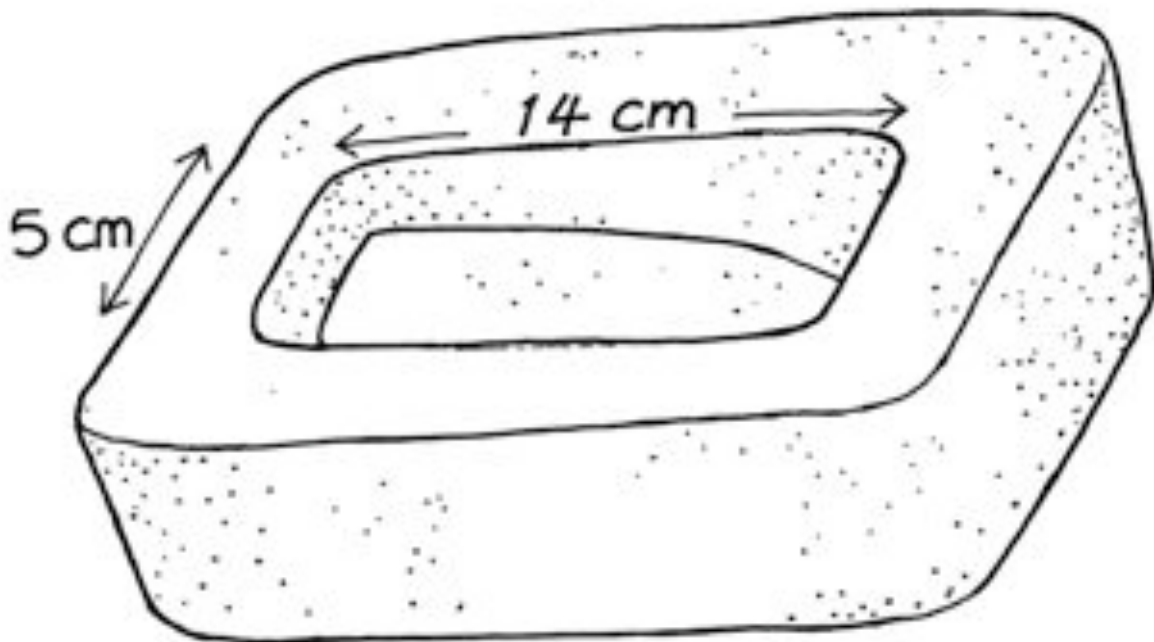

Drawings of quality control tools: cement potrest mould

To attach the pot-rest to the stove, scratch the two surfaces which are to be joined: make grooves in a crossing pattern on the back of the potrest and the surface of the stove body where you have transferred the marks.

- Attach the thin end of the pot-rest to the flat top of the stove-wall and press the potrest against the stove body. Ensure that there is no air trapped in the joints, as this can cause the pot-rest to break off during firing.
- Press the thicker end of the potrest slowly downwards against the inside of the stove wall. The potrests should protrude more on the bottom end to accommodate as well smaller pots.
- The width of the potrests should be uniform at 4 cm. Use the section between the teeth of the kamano to check.
- The upper edge should be horizontal and flat so that large pots can rest stable on the potrests. Use the 30 cm tool to get them to the same height.
- The top of the pot-rest should be 1,5 cm higher than the top edge of the stove body. You can check the height with your index finger. This distance is crucial to ensure a good draught of the hot flue gases from the fire and a good heat transfer from the gases into the pot. Therefore the hot gases must be forced against the bottom of the pot. If the potrests are too high, heat will be lost. If they are too low, the gases cannot pass and not much heat will be transferred into the pot.
- Repeat the process for the other two pot-rests and make sure all three pot-rests are the same shape and size and that all the joints are smooth and well finished.
- Note: the potrests are the major source of faults on a Chitetezo Mbaula. If they break off, the stove does not perform well any longer. Please take extra care when fixing the potrests so that they are well joined to the stove body.

#### Door:

- Finally cut out the door using the spoke: Pierce the spoke through the stove wall on the marked line. Hold the spoke with both hands (one inside, one outside), keeping the spoke horizontally to ensure that the inner door measurement is approximately the same as the outer one. Then cut along the marked line and remove the clay cut out. There should be no 'step' at the entrance, the floor level should be even.

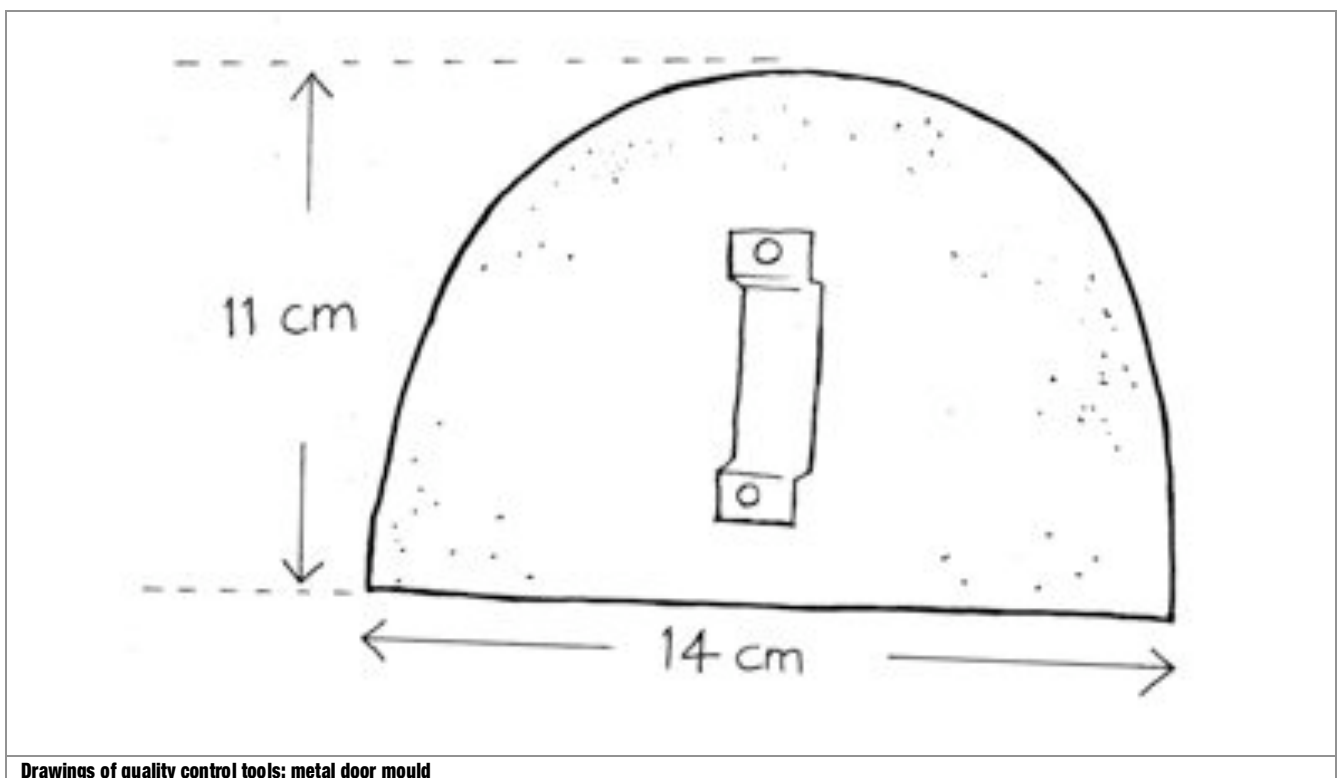

Drawings of quality control tools: metal door mould

- Smoothen the edges of the door and the floor of the fire chamber. This can be done simply with a finger or with a small piece of wet sponge, a mango pip, a small bamboo piece or small piece of plastic plate.

### Decoration

- The main features of the stove are now complete, so you can give the stove some final touches to make it look attractive. The stove has to be attractive and functional. If you want to sell it, someone has to like its appearance to want to buy it. So smoothen the stove again, insides and outside, using a little water and a smooth tool. Add some decoration if you like, as long as this does not alter the features and functionality of the stove.

### Serial number:

- Before you leave the stove to dry: scratch in the serial number into the moist clay so that it is well readable. This number should identify where and when the stove was made. Make sure you use every number only once so that each stove has a unique number and can be easily attributed to its place of origin. If you are producing stoves in a group, consult with your secretary on the numbering system.
- Serial numbers are important to allow stoves to be traced. At a production level it may be important to track errors in production. It could be the source of the clay that is a problematic. Where did the clay come from (e.g. the anthill near the borehole)? Tracking – did the stove conform to standard of 14 days of drying? How many stoves came out of that batch. Noted in a hardcover notebook kept by the producer group.
- The serial name is also important for stove marketing and for tracking sales. For carbon purposes the serial number is one of the key pieces of information and with the name of the end-user makes the stove traceable. Serial numbers help to identify a particular stove. If people come to verify. Stove has a serial number etched on it. That is copied onto a receipt. That number is entered into a database. The serial number should tally or match with the end-user.
- It has been agreed at Stove Camp 20012 to standardise serial umbers for stoves as follows: District / Company or organisation / Production group or kiln / Stove number. E.g. KA / SH / 01 / 024 is the twenty-fourth stove that has been made in Group number one in Karonga under the facilitation of Self Help Africa.



**Make sure to add the serial (identification) number before the stove dries out.**

### 1.7 - Drying the Stoves

Dry the stoves slowly for three to four weeks. For the first week, the stove should be drying on a flat surface like a piece of plywood to prevent any deformation of the clay while it is still moist. If the climate is hot and dry, cover the stoves with polyethene sheets, sacking or banana leaves for the first week to prevent them from drying too fast and cracking. If the climate is damp, the stoves can be left to dry without being covered. Normally after a week the stoves are dry enough to be turned upside down on the potrests, so that air can ventilate inside to dry the bottom of the stove.

After two weeks the stoves should be hard enough to be stacked on top of each other to save drying space. The stoves should be stacked always with the same sides touching each other: bottom on bottom, potrest on potrests, offsetting the stoves so that the potrests always rest on the stove wall and not on another potrest. Do not stack more than 4 stoves to prevent that the bottom stoves get deformed by the weight of the other ones on top.

When the stoves look and feel completely dry they can be prepared for firing: put them outside on a dry surface for final drying in the sun for a day or two. If the weather is not conducive but the stoves need to be urgently fired to satisfy orders, the stoves can be placed in the kiln already and dried out for a day with a very slow fire while the kiln is still open on the top to let the moisture escape. Do not heat the stoves more than what you can touch with your hands.

**Please note:** Stoves have much thicker walls than traditional pots. This means that they will take longer to dry. It is important to dry the stoves as slowly and evenly as possible. Otherwise they are likely to crack.

DO NOT	DO
Put wet stoves in direct sunlight to dry; Put wet stoves in a draughty or windy place to dry; Put wet stoves directly on a cement floor as they will stick; Put wet stoves in a hot tin-roofed shed without covering them.	Put wet stoves in a cool humid place for first few days of drying; Put cardboard, sacking, cloth, dried grass or leaves under the stoves, especially if they are to stand on a cement floor; Cover wet stoves for the first few days of drying with sacking, cloth, cardboard or even banana leaves. If you use polyethene, make small holes in it to allow some moisture to escape.

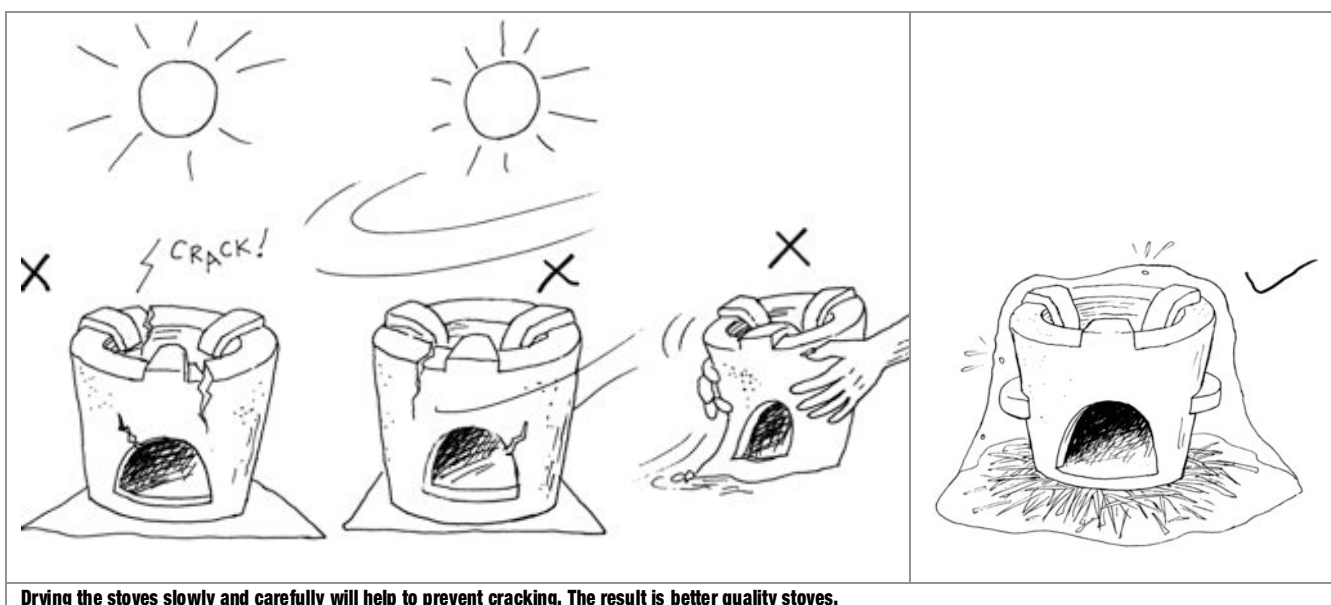

Drying the stoves slowly and carefully will help to prevent cracking. The result is better quality stoves.

## 1.8 - Firing the Stove in a kiln

Your stove is now ready for firing! Before firing, make sure that you do a quality control check. Check each stove for cracks or other defects. If stoves have small cracks at this stage, most probably they will break during firing. If you fire a poor quality stove, you will be wasting both the clay and fuel. Remember that you can re-use the clay from any stove you reject before firing. Make sure to write and etch in the stove's reference number **before** firing.

Firing is the process of baking sun-dried clay into pottery. During firing, the clay structure changes and becomes a brittle substance which will no longer dissolve in water. Most clays change colour during firing. Because of its thicker wall, stoves need to be fired for a longer period of time as compared to most traditional pottery products. The total firing time is, of course, much longer as it includes the heating and cooling time.

While you can never totally prevent stoves from cracking during firing, you can minimise these losses. It is realistic to expect a few stoves to crack. If fewer than 10% of the stoves crack during firing, then you are on the right track. Stoves will crack if the temperature in the kiln rises too fast as the firing begins. If any remaining water in the clay reaches boiling point too quickly, it gets trapped, expanding suddenly as it becomes steam, cracking the stove. The clay itself also expands as it is heated. If this happens too fast, the liner may crack.

Cracking will also occur if the temperature in the kiln drops too fast during cooling. This is because the pottery will contract suddenly and crack. Stoves may also crack if heated unevenly. This could happen if the temperature rises too fast on one side of the kiln or if the kiln cools down unevenly due to wind or draught.

### Improve firing:

Start with a small fire, then slowly increase the temperature. Make sure that there is even distribution of heat during firing. Let the kiln cool for a whole day after firing before offloading. The stoves must not suffer a temperature shock when taken out of the kiln, as they might crack with quick changes in temperature.

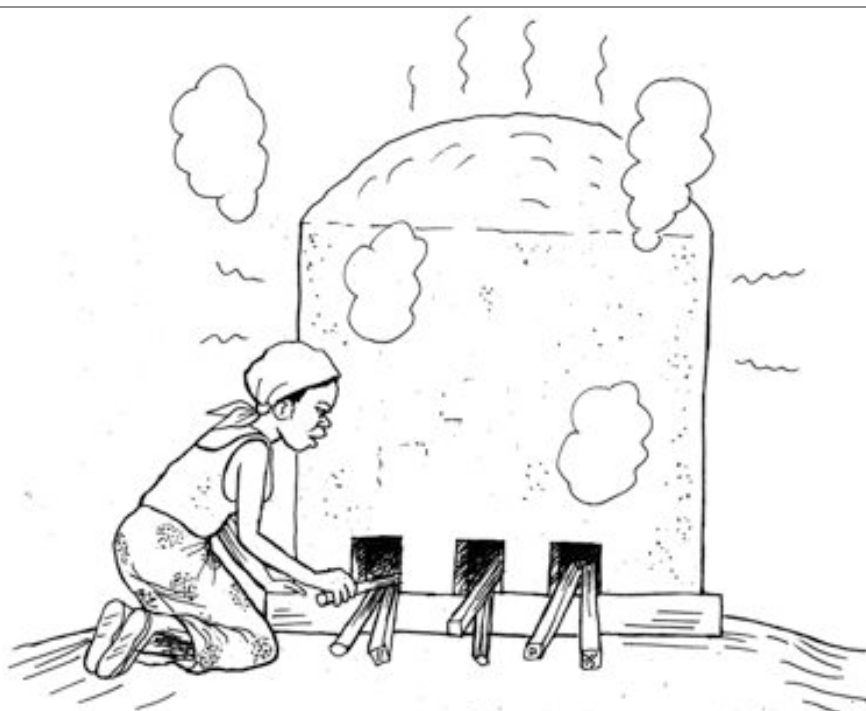

Firing stoves in a kiln rather than in an open fire saves firewood and reduces losses of stoves through cracking.

Stoves have thick walls and you should be careful that they are properly fired. Partially fired stoves appear alright, but will crumble when they get wet or after a short period of use. If you hold a stove with one hand and knock on it with a knuckle, or using a short stick, it should sound like a bell. An under-fired stove will sound dull.

### Fuel for firing

Given that improved cooking stoves' aim is, among other things, to reduce the amount of wood fuel required for cooking, this fact should also be considered during the production phase. Firewood, bamboo and dry grass are the main sources of fuel for firing. Agricultural waste such as stalks and leaves may also be used, especially in the initial phase.

You can reduce the fuel needed for firing by (1) Retaining the heat in the kiln by enclosing the fire, (2) Improving the combustion of the fuel by ensuring that sufficient air reaches the fire, and (3) Firing a large number of stoves together. This would mean having an appropriate sized kiln in which you would fire a full load of stoves each time.

#### Did you know?

It only takes around 2 kgs of wood to fire a Chitetezo Mbaula, that saves 995 kgs of wood per year and has a life span of several years!

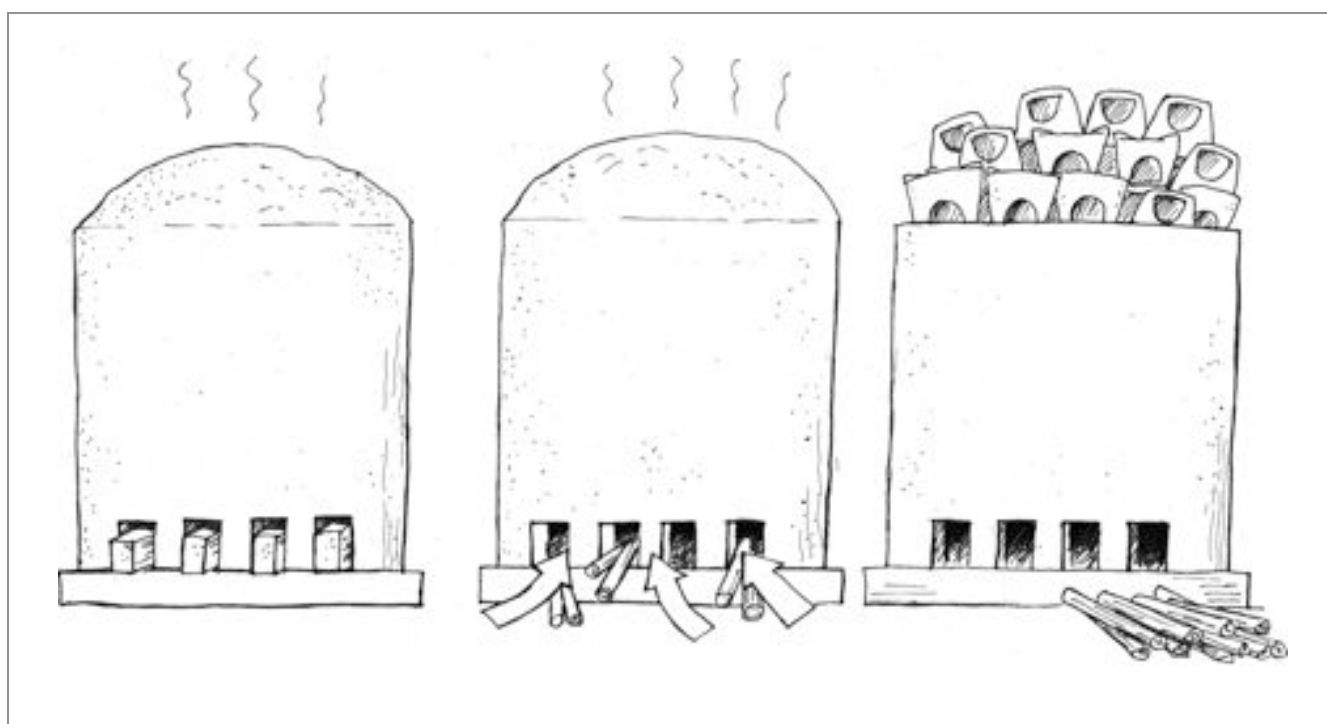

**Fuel-efficient firing is made possible by the fuel-efficient kiln that retains heat, improves combustion and allows firing of a large amount of stoves at the same time.**

## 1.9 - Fuel-efficient Kiln

A fuel-efficient kiln is a rather large production asset that is best used when filled to capacity to save firewood. So it makes sense that several stove producers share one kiln. Combining stoves from several producers will allow more frequent firings than if one person had to produce a full kiln load before being able to fire them. A sheltered kiln will allow producers to fire stoves also in the wet season.

It is important that members of the production group or at least a builder from the village is trained on how to build a fuel-efficient kiln in order to build up local capacity to maintain the kiln over time.

The fuel-efficient kiln consists of: (1) Foundation – a solid base which raises the kiln slightly above ground level to keep the base of the kiln dry, (2) Fireboxes or fire-channels where the fire burns and wood can be added without disturbing the loaded stoves, (3) Floor – the area above the fireboxes where the first layer of stoves sit, (4) Wall – the outer wall of the kiln, (5) Mud dome – dome shaped made of grass and mud which reduces heat losses from the top of the kiln, and (6) Firing chamber – the space inside the kiln above the fireboxes, where the stoves are fired.

The materials necessary for constructing the kiln include:

Fired clay building bricks	Fine sand	Anthill soil
Polythene (plastic) sheets	Water	Murram (clay gravel / laterite mix)
Stones or crushed brick		

Wire mesh to strengthen the wall is optional. The quantity of materials required for constructing the kiln will vary depending on the size of the kiln, which should be determined by the production capacity of the producers and the number of stoves to be fired at once: the kiln is scalable yet an uneven number of fireboxes is recommended to assist in a symmetrical heating of the kiln. The fireboxes should be 18 cm wide so that the Chitetezo Mbaulas can span that width. The thickness of the kiln wall should be one length of bricks, or at least 10 inches for insulation and durability.

It is important to build the kiln on a suitable site with the following (1) **Good drainage** – so that the kiln and its foundation are not under water in the wet season (2) **Storage space** – for stacking stoves and storing wood fuel, and (3) **Safety** – so that sparks and smoke emitted during use do not affect homes or surrounding trees.

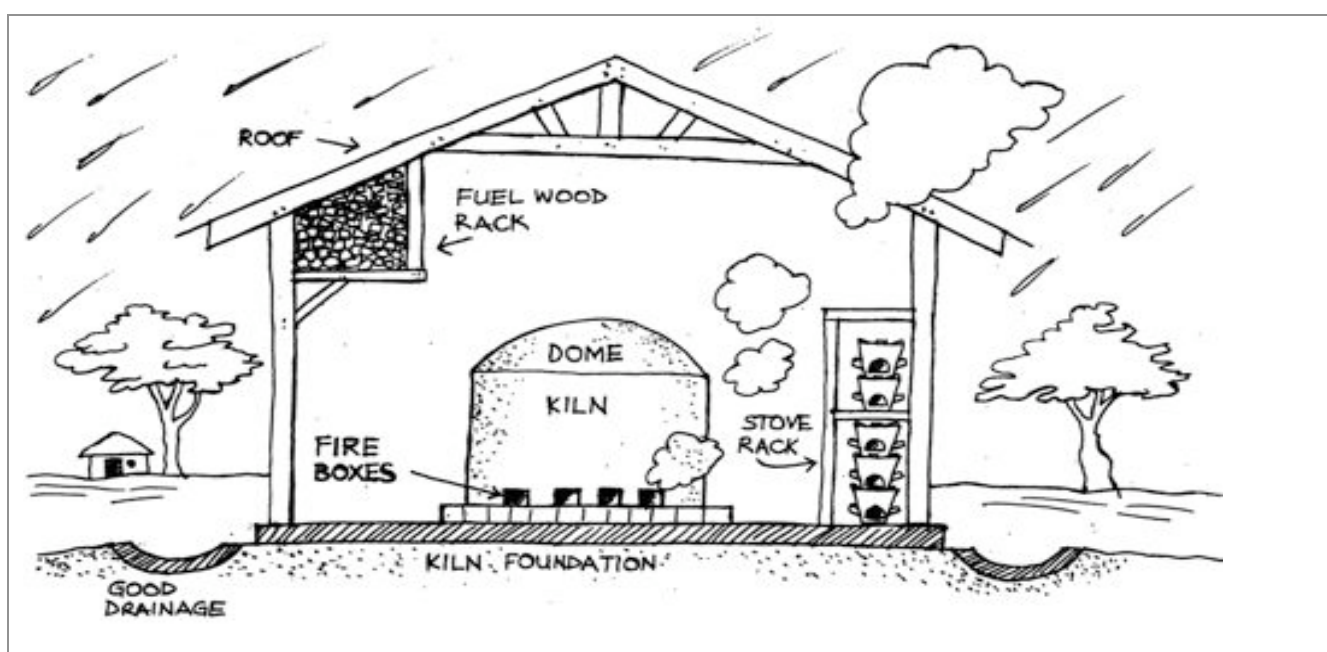

Protect the kiln from the elements ensuring that there is good ventilation and locate the kiln in an area that is protected from flooding.

The kiln should be oriented so that the fire-channels are perpendicular to the prevailing wind direction to prevent the wind to blow right through the channels.

Good quality materials and care in construction will result in a long lasting and effective kiln. The inside of the kiln should be plastered to protect it from the fire. The kiln should be allowed to dry for up to four weeks. Before the first use, drying should be completed by lighting small fires in the kiln. A simple shelter can be constructed to protect the kiln.

The tools and equipment used for construction are:		
Rammer	Builder's line	Mason's hammer & trowel
Pick	Plumb line	Spade or hoe
Tape measure	Spirit level	Wheelbarrow

### Tips for using the fuel-efficient kiln:

- Ensure that firewood used for firing is dry;
- Do not overload the kiln, otherwise some stoves will be under-fired';
- Put the first layer of stoves into the chamber with the bottoms of the stoves resting on the firebox bricks;
- The remaining stoves do not have to be packed neatly, but should not be able to move easily. The amount of "free" space in the kiln should also be kept at a minimum so that energy will not be wasted during the firing process;
- Stoves can be loaded above the level of kiln wall to form a dome shape which will be covered by mud before firing;
- Allow temperature to rise slowly for two to three hours and then maintain at a steady level for another six hours;
- Check the bottom layer of stoves by looking through the firebox doors: if the stoves are 'glowing', the firing process is nearly complete.

The stoves should be cool enough to handle within 20 – 24 hours after firing is complete. The mud dome must first be removed before carefully unloading the stoves. Be sure not to open the kiln too early so that it does not cool too fast and cause breakages. After each firing, inspect the kiln for (1) bricks that are beginning to sink, (2) joints which have become loose or have fallen out, and (3) cracks. Any of these should be repaired immediately, and the kiln maintained by re-plastering on a fairly regular basis.

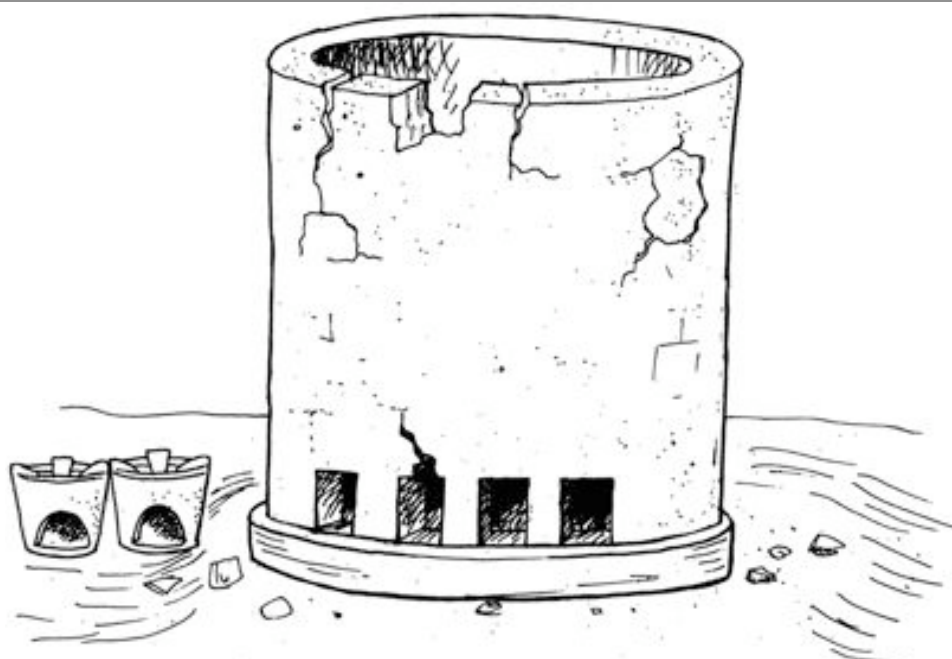

**A kiln should be protected from the rains to prevent deterioration. Regular re-plastering to fix the cracks is recommended.**



## 1.10 - Avoiding changes in design (design drift)

The Chitetezo Mbaula has been designed over years to be affordable, accessible, to meet local preferences and to maximise efficiency. Although final dimensions will vary according to the shrinkage of the clay in the process of drying and firing, correct **dimensions** are critical for proper functionality of the stove and to prevent efficiency loss.

If the **firebox height** is too low (less than 18 cm), the fire will not have enough space to develop properly and will choke. If the stove is too high, the heat transmission from the fire to the pot will not be the best possible, the fire will be wasteful and the stove will be unstable. The hottest point of a fire is not at the end of the yellow flames, but above the end of the flames. Heat transfer can happen when (1) hot gases hit the bottom of the cooking pot and heat is transferred by 'rubbing' against the pot surface as much as possible (i.e. convective heat) and (2) radiant heat from the glowing ember. The distance from the pot to the embers should not be more than 15 cm (normally embers pile up on the stove floor and therefore raise above the stove floor). The total stove height of 20-23 cm is the compromise between stability, convective and radiant heat optimum.

If the **wall** of the stove body is too thick, the stove will be very heavy, uses a lot of clay and is more likely to burst in the firing process. If the stove wall is too thin then the stove wall might not be able to support a heavy pot and collapse.

If the **door** is too wide the part above the door is likely to sink down during drying and deform the stove. Cracks are likely to form and eventually lead to breakages above the stove door. There will not be enough support for the weight of a heavy pot. If the door is too small, the fire will not get enough air to burn properly and there will be a lot of smoke. If the door is too big, the draught will be too strong and will use up a lot of firewood. If the door is too high, the stove wall above the door will become weak. This is the point where a stove is most likely to crack.

If the **pot-rests** are too low (lower than 1.5 cm or one finger) , the gap between the pot and the firebox is not big enough to let the hot gases out of the firebox. This will lead to a smoky and choking fire. If the pot-rest is too high, the gap will be too big and the hot gases can escape from the firebox without making proper contact with the pot. This would mean that the heat transfer from the hot gases into the pot would be reduced and the hot gases can be blown away by wind underneath the pot..

It is important that the **gap** between the pot and the stove body is the same in all places, otherwise there is more draught in some places than in others: this might lead to unequal burning of the fire and to burning of the food in the pot.

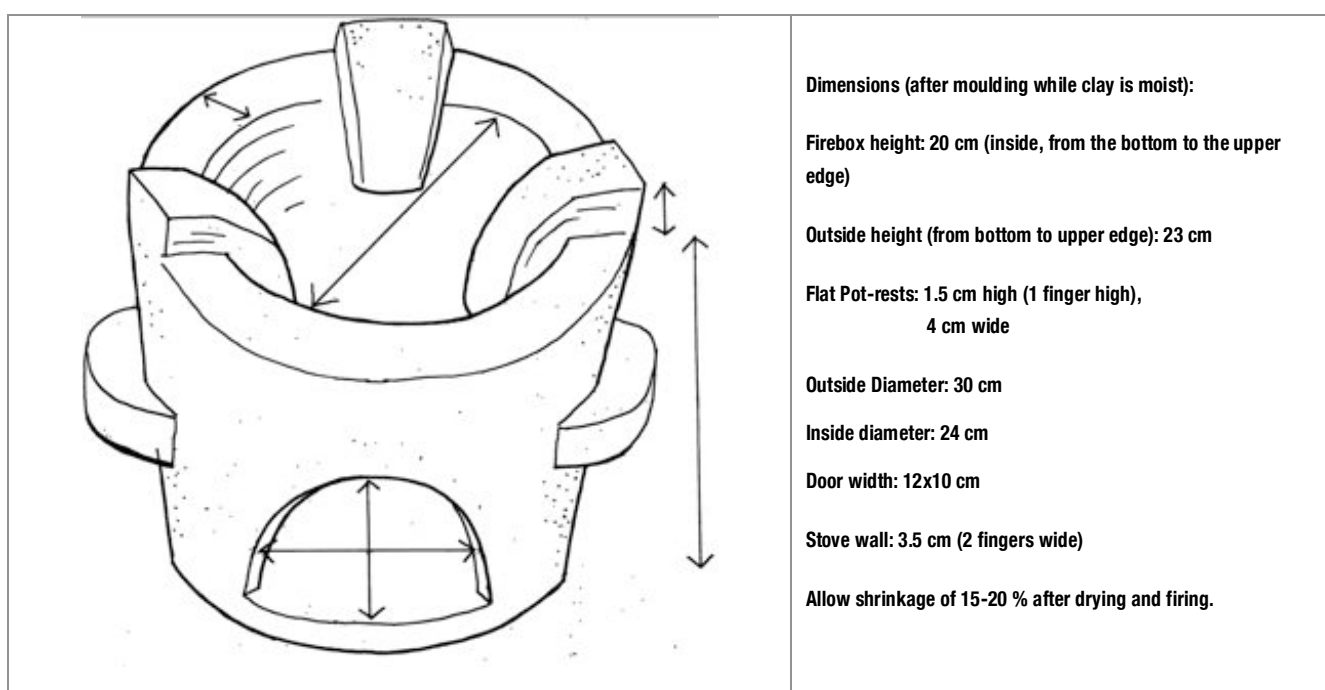

## CHITETEO MBAULA DRAFT GUIDELINES

### CHAPTER TWO – HOW TO SELL A CHITETEO MBAULA

#### CONTENTS

<b>2.1 - Objectives .....</b>	<b>26</b>
<b>2.2 – Background .....</b>	<b>27</b>
<b>2.3 - Stove design theory .....</b>	<b>28</b>
<b>2.4 – Chitetezo Mbaula – technology .....</b>	<b>30</b>
<b>2.5 - Improved firewood practices .....</b>	<b>32</b>
<b>2.6 - Improved kitchen practices .....</b>	<b>33</b>
<b>2.7 - Improved cooking practices.....</b>	<b>34</b>
<b>2.8 – Real time data for continuous improvement .....</b>	<b>35</b>
<b>2.9 – Tapping into local entrepreneurial talent.....</b>	<b>36</b>
<b>2.10 – Social marketing – making Chitetezo Mbaula aspirational .....</b>	<b>36</b>
<b>2.11 – Cost and price of stove .....</b>	<b>37</b>

#### 2.1 - Objectives

It is important for field extension staff and stove promoters of the Chitetezo Mbaula to understand the basic technical aspects of how stoves work and what makes it an efficient stove. It is equally important to understand how to use the improved stove properly in order to maximise the fuel savings. Good practices such as good kitchen management and firewood management are as important as the technology of the fuel efficient stoves, and it is important to share these messages with new stove users.

The purpose of this manual is to provide field facilitators with an understanding of how the stoves work to enable them to train and motivate village based stove promoters and retailers.

By the end of the training, field facilitators should:

- Appreciate some of the reasons why the three stone fireplace is so widely used;
- Understand the basic theories of combustion (how fire burns) and heat transfer in relation to wood burning stoves;
- Understand the technical design of Chitetezo Mbaula and how it works;
- Appreciate that improved kitchen and firewood management are also key for saving fuel;
- Appreciate the importance of real-time data, promoting local entrepreneurs and social marketing.

## 2.2 – Background

The cooking of food requires heat, which in the context of a Malawian village is done by using firewood. Due to an increasing population there is growing pressure on Malawi's trees which are used for firewood resulting in forest degradation, higher wood prices and longer distances to find wood fuel for domestic use. The 'three-stone' fire cooking method, which is commonly used in rural Malawi, uses up a lot of wood fuel.

There have been several developments to help with wood fuel scarcity and related challenges through promoting improved ways of cooking, which burn wood more efficiently. The promotion of improved cook stoves is further supported by providing information on improved kitchen management practices. This helps to reduce firewood consumption and cooking time while at the same time bringing other sustainable development benefits such as reduced exposure to smoke in the kitchen and reduced burden on households, particularly woman and children.

This guidebook has been prepared for technical field staff who promote the purchase and proper use of Chitetezo stoves. No previous experience or knowledge of improved stoves is necessary although any such experience will be an added advantage. It is expected that this guide will, with time and more experience include feedback from field staff and end-users.

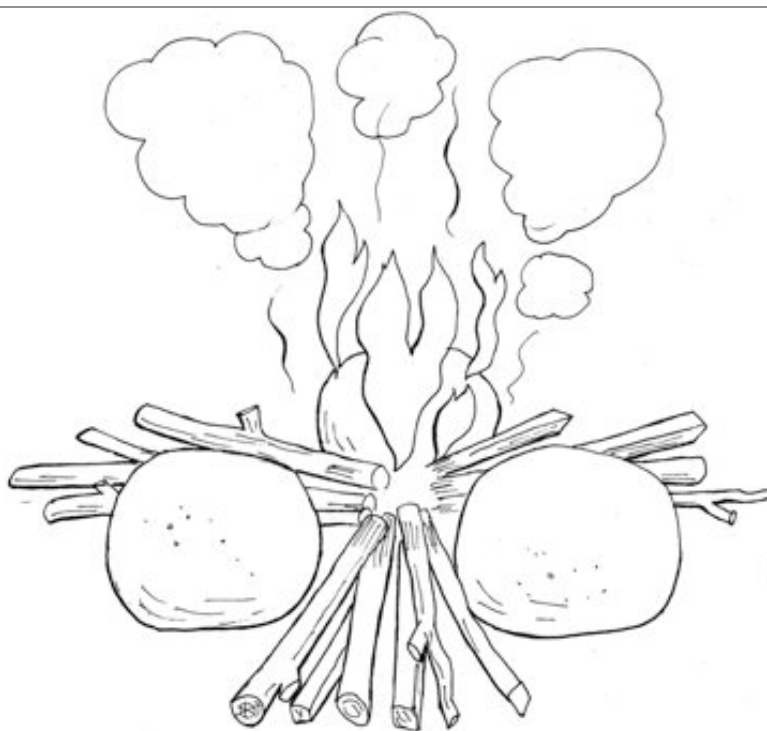

**A three-stone-fire, currently the most common way to cook with firewood, not only in rural Malawi.**

## 2.3 - Stove design theory

### The three stone fire

Advantages	Disadvantages
Can be assembled almost anywhere with few resources Easy to light Can use / burn damp fuel Fast cooking Easy to move Can be used for many cooking purposes e.g. roasting, beer brewing and can accommodate various pot sizes Little or no skills needed to build/ use/ maintain Also provides light and heat Can use agricultural waste as fuel	Smokey Dangerous for cooks and children Dirty, spreading ashes Pots are difficult to clean after use Uses plenty of wood Heat is lost especially when it is windy Stones are portable but fire is not

The advantages list is likely to be longer than the disadvantage list because the three stone fireplace is in fact a very adaptable technology. This is why it is still so widely used in many parts of the world. We should therefore not underestimate this traditional technology as we try to promote the purchase and proper use of an improved stove.

To be able to sell the virtues of improved cook stoves it is important to understand the benefits of the Chitetezo Mbaula. To do this it is good to know how a fire burns. The three essential elements for fire to burn are (1) fuel (in this case firewood), (2) oxygen and (3) heat (because it takes an initial heat input to start a fire). If any of these ingredients is not there in sufficient quantity, the fire will not burn properly.

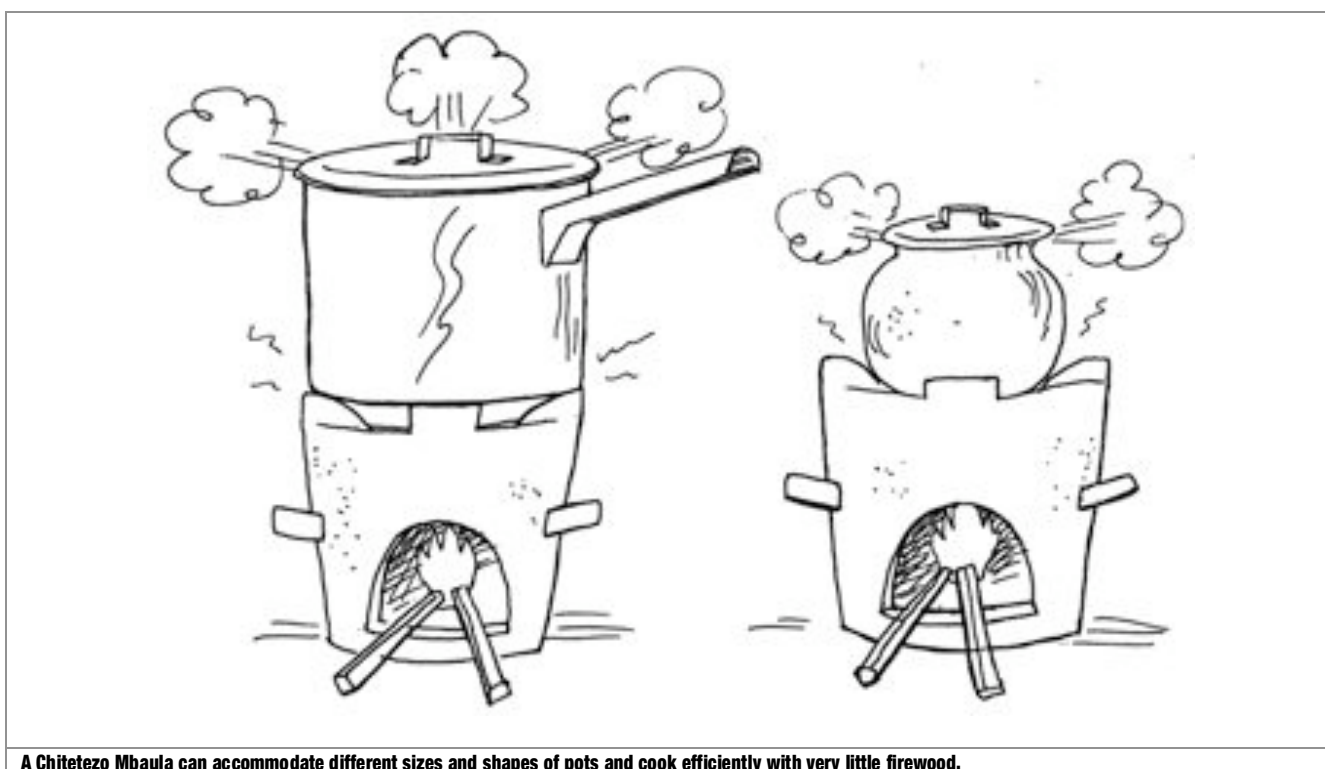

**A Chitetezo Mbaula can accommodate different sizes and shapes of pots and cook efficiently with very little firewood.**

## Stages of combustion

1. First, the heat removes any moisture in the firewood,
2. Then the wood releases gases (*mafuta*),
3. The gases mix with the air (oxygen) and burn with yellow flames giving off some heat. If there is not enough air or heat or space the gases will leave the fire as smoke. Yet with too much cold wind, the fire may become so cool that it cannot burn and goes out.
4. Finally, the remaining charcoal burns with a red glow (and tiny blue flames) radiating off a lot of heat. But if there is not enough air going into the fire, or if the fire is not hot enough the charcoal will not burn, and will produce poisonous carbon monoxide (CO) instead of carbon dioxide. If all the charcoal is burnt then only ashes will remain.

All these four stages are happening at once in different parts/places in a fire. If hot charcoal and burning wood are close together the fire will burn well with little smoke. But if the fire is spread out it will become smoky and can die.

## Implications on stove design and use are:

- Dry fuel gives better, more efficient combustion (burning). No heat is wasted to evaporate the moisture.
- A sheltered fire burning area or combustion chamber is important to ensure space and time for the gasses to mix with oxygen while they are still hot enough to burn. Size and height of a fire-chamber matter.
- If the cooking pot is far from the fire it will get less heat, but if it is too close the fire will not burn properly; so the fire area must be the right height.
- A small, hot fire gives burns better provided there is enough oxygen to achieve a complete combustion.
- There must be an outlet for the combustion gases so that a fresh supply of oxygen is drawn into the stove.
- The pot-rests are the interface between the combustion chamber and the pot. Their dimensions are very crucial: if there is not enough draught, the fire will choke. If there is too much, the hot combustion gases will not have good contact with the pot and will not be able to transfer the heat into the pot.
- The firebox door must be large enough to ensure an adequate supply of oxygen. Yet, it must not be too big, to avoid excessive air cooling the fire and dilute the hot combustion gases.



**The pot-rests are the interface between the stove and the pot. They are crucial to ensure the appropriate draught and heat transfer.**

## 2.4 – Chitetezo Mbaula – technology

This is a portable stove made from clay that has been designed to make cooking easier, faster and safer for the user, while using less wood fuel for cooking. They also look nicer and cleaner in the kitchen. Chitetezo Mbaulas are often quicker to light and meet the specific needs of the user, e.g. they make the fire portable, easy to carry out of the rain.

When using the Chitetezo Mbaula the pots, kitchen and surrounding areas are cleaner and therefore more hygienic because of the reduced smoke and soot as the fire burns. Women and children, who are most exposed to smoke from the stove, benefit. In addition, less time and effort is spent on collecting fuel because the stoves use smaller and less wood fuel. Men become more concerned with household issues and women's social standings improve.

Chitetezo Mbaula is not only better for the user but also good for the environment. Since it burns firewood more efficiently, it means that less trees are needed for firewood and the pressure on forests is reduced. Furthermore, the stoves can create a hot fire from many low-grade fuels like twigs, grass, maize cobs, stalks from pigeon peas etc.,.

### Know your Stove

**Fuel** - It is designed to burn wood although it can also burn crop waste such as maize stalks, pigeon pea stalks, maize cobs and animal dung. Fuel is fed into the fire through the fire-door in the front.

**Smoke** - Smoke is unburnt fuel. As long as the firewood is dry the Chitetezo Mbaula produces less smoke than three stone fires, because it creates a hotter fire in the combustion chamber and burns the fuel more completely. .

**Pot-flexibility** - It can accommodate one pot at a time. Because of the design of the pot-rests, the stove can accommodate small, medium and large cooking pots. Pots can have round or flat bottoms and be from metal or clay.

**Mobility** - The stove has got handles on the sides and can be carried even during the cooking process. It has a floor so that the fire can be carried with the stove, unlike with the 3-stone fire. A pot-holder should be used if the stove is hot.

**Material and costs** - Locally found pottery clay, which is available at little or no cost, is used for production of the stove. Firing of the stove requires only 2-3 kg of firewood but makes it hard and more durable.

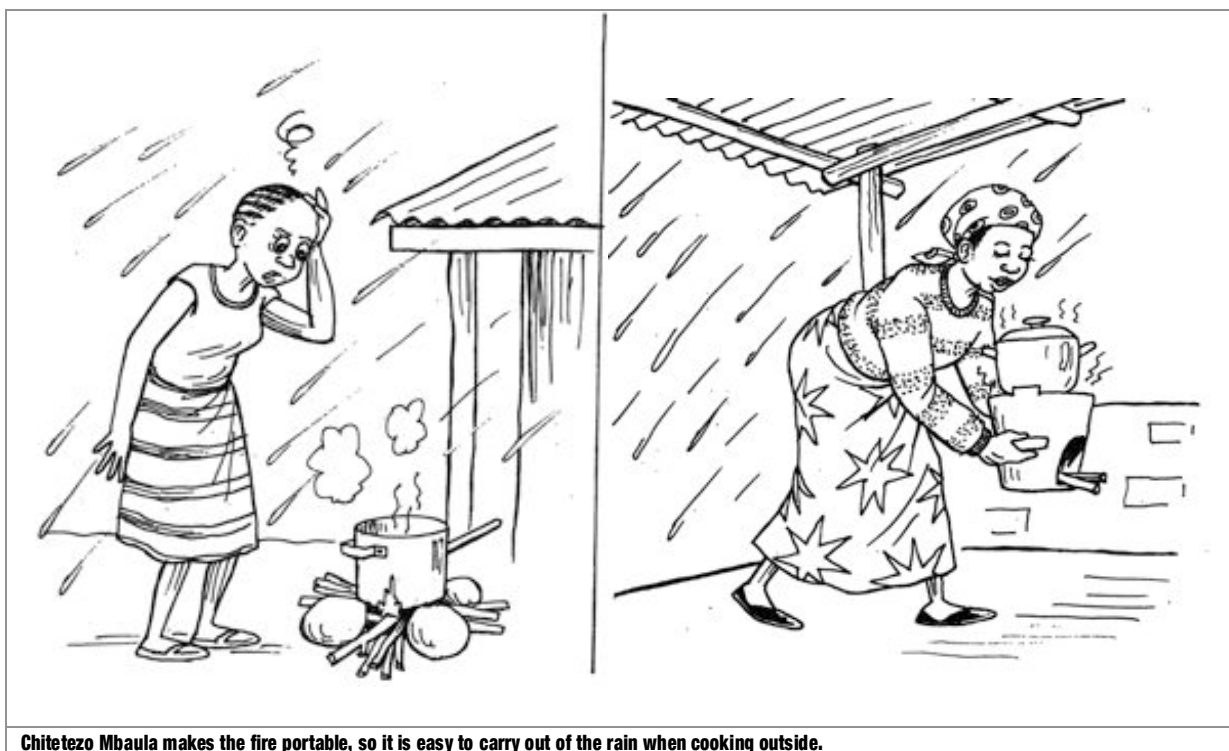

**Chitetezo Mbaula makes the fire portable, so it is easy to carry out of the rain when cooking outside.**

### Benefits of using the stove

- Uses less firewood
- Less time, effort and hard work collecting wood
- Quicker cooking time
- Cleaner – less smoke and less ash
- Safer – risks of burns and scalds are fewer
- Raises awareness about importance of energy conservation and fuel security
- Less pressure on natural resources locally which also serve to improve soil fertility and reduce forest degradation, soil erosion and desertification.
- Can use a great variety of alternative sources of fuel that are easier to find or grow such as crop and forestry residues: corn cobs, nut shells, stalks from pigeon peas, maize, sorghum etc, leaves, twigs and tree prunings, especially from agroforestry species such as *grilicidia*, *tephrosia* and *sesbania sesban*. These have other benefits to the household such as increasing soil fertility, which may increase food production. The list of fuels is nearly endless and includes many plants that not only provide fuel but also food, like the pigeon peas.
- Helps our climate

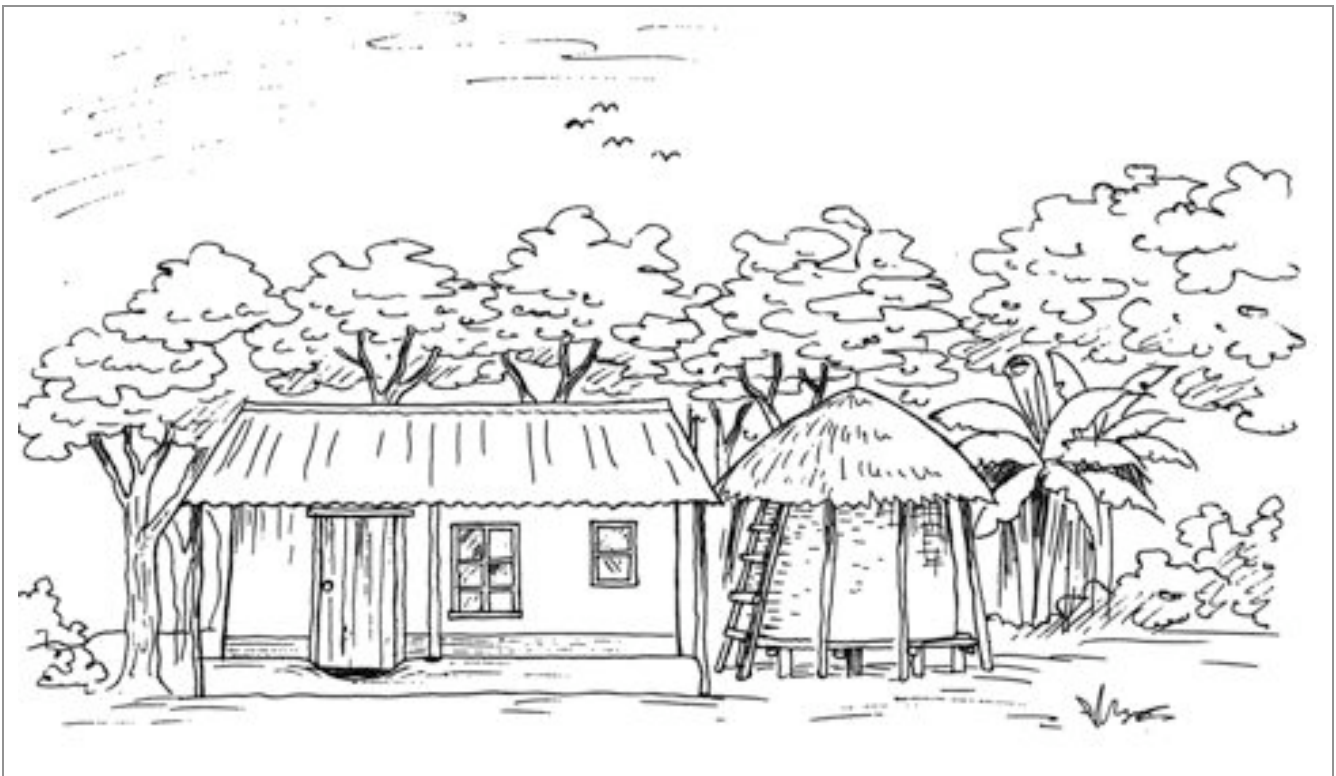

Chitetezo Mbaula not only protects the users from burns but also plants and trees to make our living space more comfortable.

## 2.5 - Improved firewood practices

Split wood into smaller pieces: Smaller pieces of wood take less time to dry. Smaller pieces burn better because they have a bigger surface and better contact with the air that is necessary for the burning process. It is also easy to adjust firewood input when using smaller pieces.

Dry firewood very well in the bright sun: freshly cut wood contains a lot of water; it is wet. When you burn wet wood, energy is lost in drying the wood instead of heating up your food. When you use dry firewood, the full energy content is used to heat what is in the pot and make more efficient use of the firewood. Leaves, twigs, grass, maize stalks and other agricultural residues can also be used.

Store a stock of firewood in a dry place: Make sure that you protect already dried wood from rains. The drying process continues even if the firewood is stacked. Dry firewood will result in maximum use of the energy contained in the wood.

Start the fire with few sticks of firewood: It will take some time until the stove is hot. During the heat-up phase the stove will absorb heat from the fire. In that phase the fire will be cooler and may not burn completely, so that you might experience some smoke. Once it is hot, the fire will burn well and the stove will not take up any more heat from the fire, there will be little or no smoke and the heat will go mainly to your pot. For heating up the stove in this initial phase, a few sticks are enough. By restricting the number of sticks at the beginning, you can avoid wasting firewood.

Once the stove is hot and the fire is burning well, remove extra firewood: the fire no longer needs so much firewood to maintain the same heat. When you cook food that takes quite a long time to cook (like beans), sometimes even one stick of firewood is enough to maintain the slow heat during the simmering phase. By monitoring the fire, you can minimize the use of firewood and avoid waste.

Keep firewood that is not completely burnt after cooking for further food preparations: Once you have finished cooking and the pot is no longer on the stove, there is no need to keep the fire burning. This firewood can be saved for the next cooking: extinguish it in a small pile of sand and keep it for the next time you light the fire.

Grow your own fuel in the garden. Use plants that give both, food and fuel. Don't cut the whole tree but only branches. Thus, the tree recovers faster and the firewood from branches dries much faster than a thick trunk.

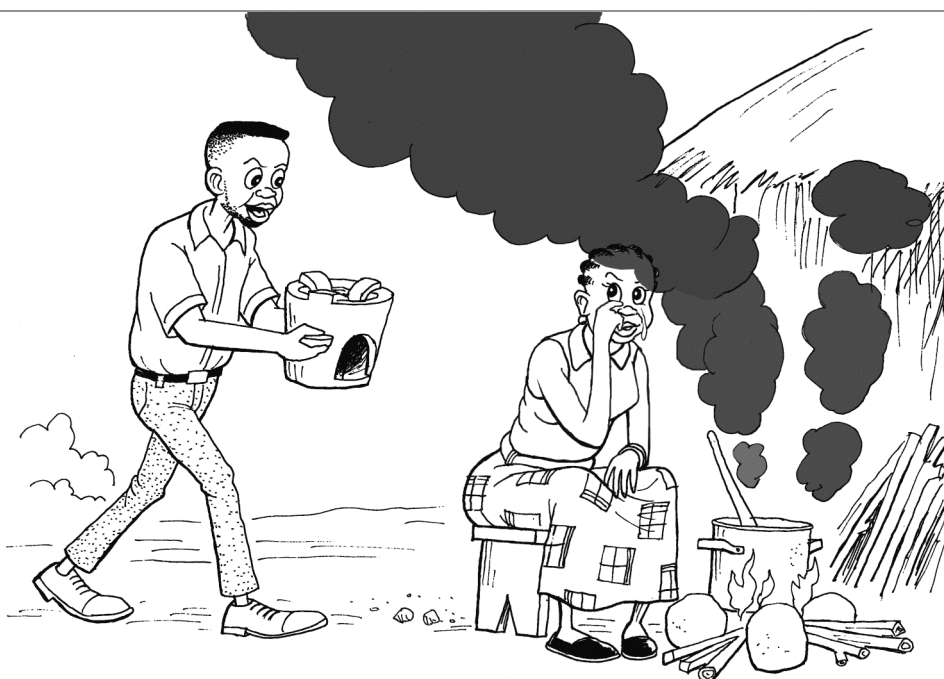

**Breathing smoke is dangerous to your health. Smoke can kill! It is also unburnt fuel, that is wasted. Avoiding smoke has many benefits.**



## 2.6 - Improved kitchen practices

- Have all ingredients and tools together before you start the fire: Plan ahead and think about what you need. Get all the utensils you need together. You should have all raw ingredients washed and already cut up, along with salt, oil, etc.
- Don't waste time once the fire is started: Concentrate on the cooking and don't get distracted chatting with your neighbour while the fire is burning. Put the pot on the fire as soon as it is well established. Pay attention to your food during the cooking to prevent it from burning. If you concentrate on the cooking and you keep the time, you will not need to have your fire burning for so long. Shorter time means also using less firewood.
- Ventilation: Have good ventilation in the kitchen to ensure little smoke inhalation: the ideal is to have low walls where the cook can be able to see outside while cooking. Windows on opposite walls that can provide cross-ventilation are also recommended.
- Always make sure that your stove is sheltered from the rains: This will prevent your stove from cracking and breaking.
- Keep children away from the fire: Make sure that children are not left alone in the kitchen and always supervise children whenever they are using the stove.

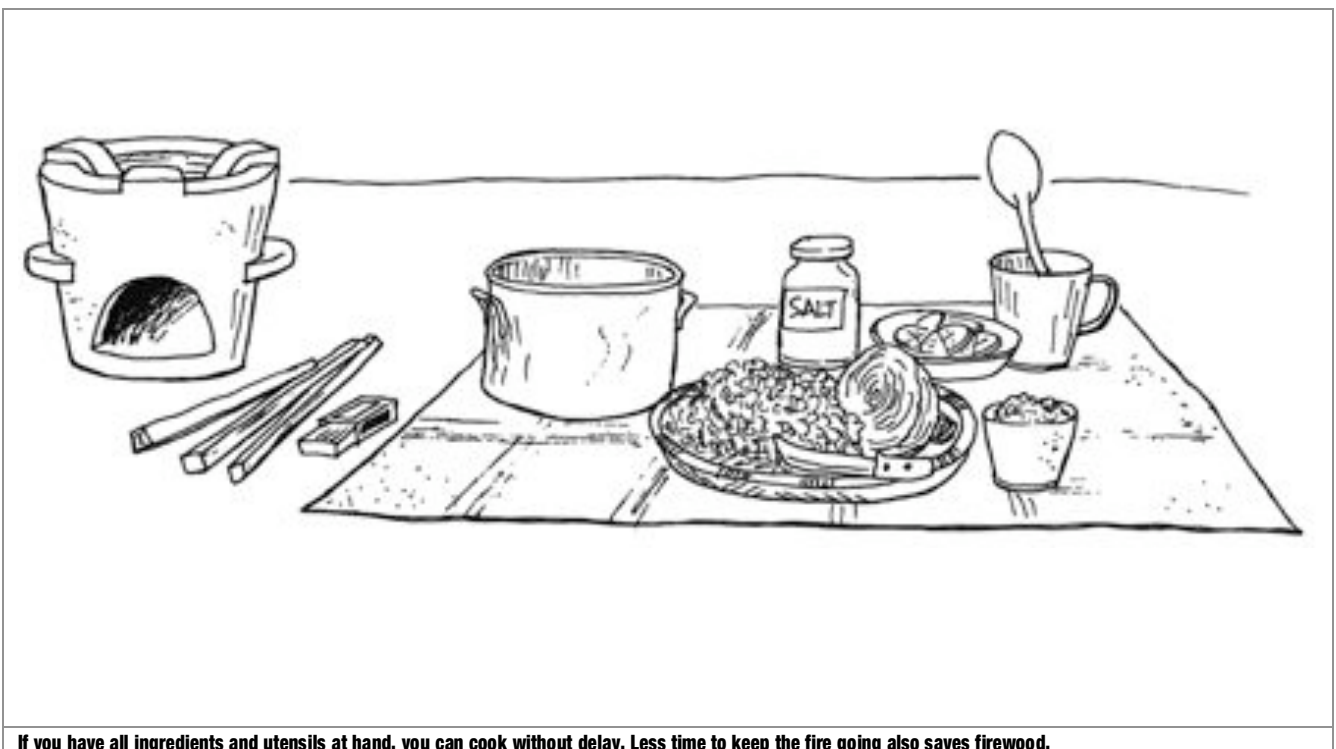

**If you have all ingredients and utensils at hand, you can cook without delay. Less time to keep the fire going also saves firewood.**

## 2.7 - Improved cooking practices

- Cover pot with lid – Trapped steam will quicken the cooking process and save fuel and conserve nutrients.
- Only use the amount of water you need – save water, save energy and its quicker to cook!
- Cook food for one longer period rather than making fire now and again.
- Do not overfill the pot.
- Do not overcook food.
- Cut ingredients into small pieces – they cook quicker than bigger pieces.
- Soak dry food overnight before cooking (e.g. dry legumes, dry cassava).
- If you will mix food after cooking, cook it together in the same pot.
- Remove surplus wood when the food has reached boiling point – you only need enough wood to maintain the heat at boiling point.
- Make use of retained heat from the stove to heat water.
- For long cooking times of food that does not need to be stirred while cooking, use a retained heat cooker or fireless cooker. It will help you to save a lot of firewood and prevent your food from burning.

Before using your Mbaula make sure you have been trained.



**Few sticks can be enough to cook. When you remove the pot, you can also remove the firewood and save it for the next time you cook.**

## 2.8 – Real time data for continuous improvement

We have a lot to learn. If we are going to scale up and make improved cook stoves accessible to hundreds of thousands of households we need to learn from innovators. Those innovators may not only come from the stove or development sectors but come from every single sector. We can apply lessons and learning for the public good.

Data that is normally collected on Chitetezo Mbaula includes the sources of clay of production, the group that produced the stove and the individual producer, the method of sales, the sales person, the buyer, the date that they bought the stoves, when the user was provided user-training, the user's village, Group Village Headman, Traditional Authority and telephone number if they have a telephone.

Take the data and use it to measure progress. Many successful companies that manage to sell their products throughout the world have a very continuous feedback loop. Once they learn something, they put it back into the product and then put it back into the market. Whole departments are dedicated to knowledge and insight. If we look at the stoves business important data can be captured on production and sales and where sales and promotional campaigns are working best. You know where every single stove is sold. Whether it was sold at a market or from a pushcart; if it was sold by a production group or by a stove promoter. If sales start to drop, then we can identify the problem and address the issue. Our learning can improve how we serve end-users.

If evaluations come at the end of the project or at the end of the year it is way too late to use the data. Not having frequent real time updates it is like trying to work in the dark, and at the end you can see the lights come on. Real time data turns on the lights. It helps informed decisions to be made before it is too late.

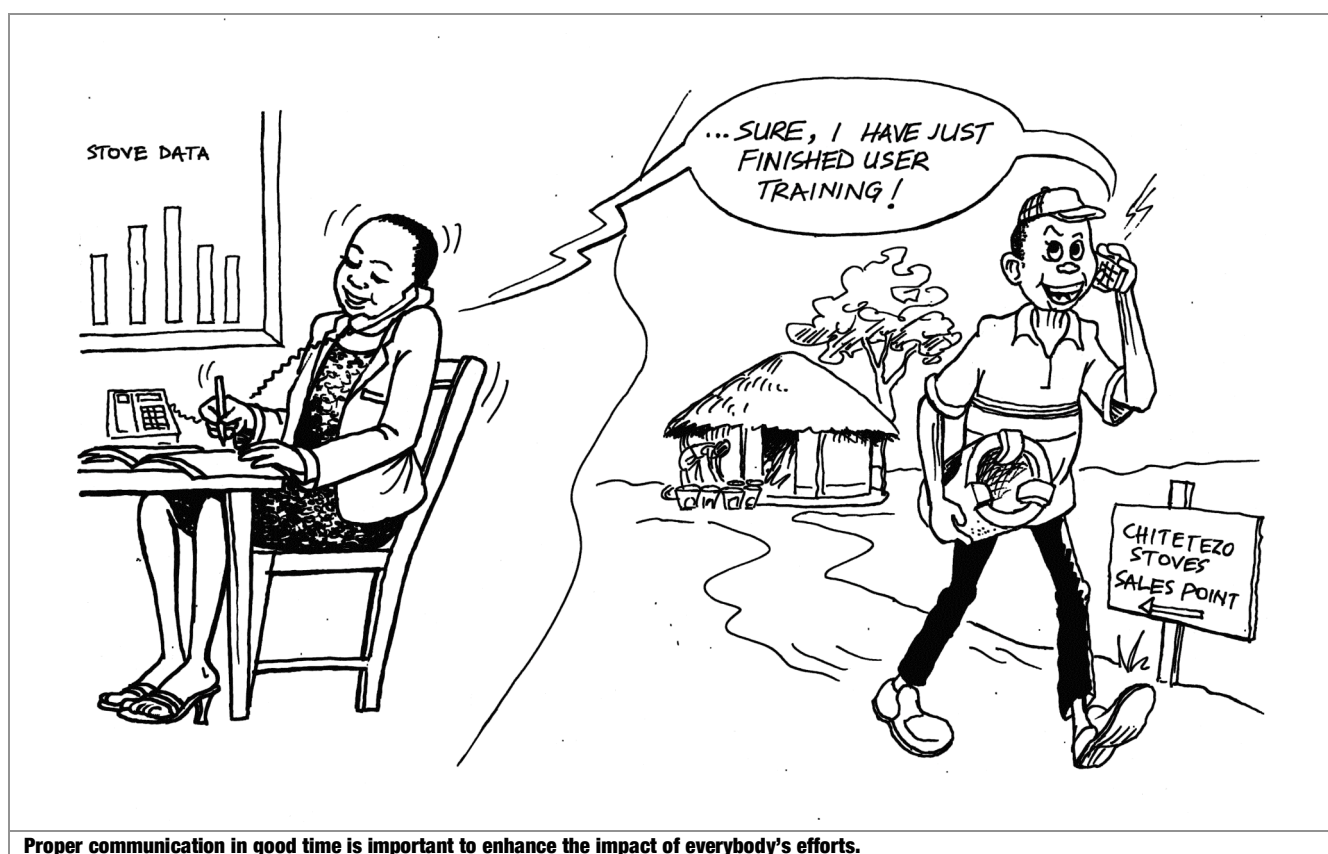

## 2.9 – Tapping into local entrepreneurial talent

Tap into local entrepreneurial talent. To reach distant markets it is important that local people can sell in the hard to reach places. Take time to learn about how to mobilise local entrepreneurs to sell and distribute stoves. Stove specific training can be provided to local entrepreneurs and in some cases small loans for working capital. Micro-distribution centres can hire sales people who use bicycles and pushcarts to get the stoves out there.

Unlock people's potential. Local entrepreneurs know how to reach the very hard to reach areas - they know what motivates their neighbours to make change. Entrepreneurs are innovative. They can identify people that they know can afford to purchase a stove at a particularly time and they offer a free trial of the stove for a couple of weeks and after that period they can return the stove if they do not want to keep it, but most buy the stove.

## 2.10 – Social marketing – making Chitetezo Mbaula aspirational

As agents of change our challenge is to mobilise behavioural change that brings about development benefits. Marketing can really help this process, if it is done well. To encourage people to adopt a new way of cooking it is important not to emphasise what they are doing now is smoky, inefficient and slow. We do not want to send out negative messages of avoidance. We are likely to be much more successful if our message is positive, upbeat and makes the Chitetezo Mbaula an aspiration – a symbol of prosperity, progress and happiness. The secret to successful marketing is to associate the Chitetezo Mbaula with the type of life people want to live.

It should feel good to have a Chitetezo Mbaula. Messages can be localised into Chichewa or the main local language. We should not make the mistake that if a person needs something they will want it. This is not always true. What does social marketing involve? Talk with the people. Take the stove and position it as a modern trendy convenience. Link stoves to what people value. Create an innovative marketing campaign. If we can start to understand what people really want. We can cause behavioural change in communities and whole Districts. Focus on how far we have come and how amazing it would be to make happen cleaner, quicker and safer cooking.

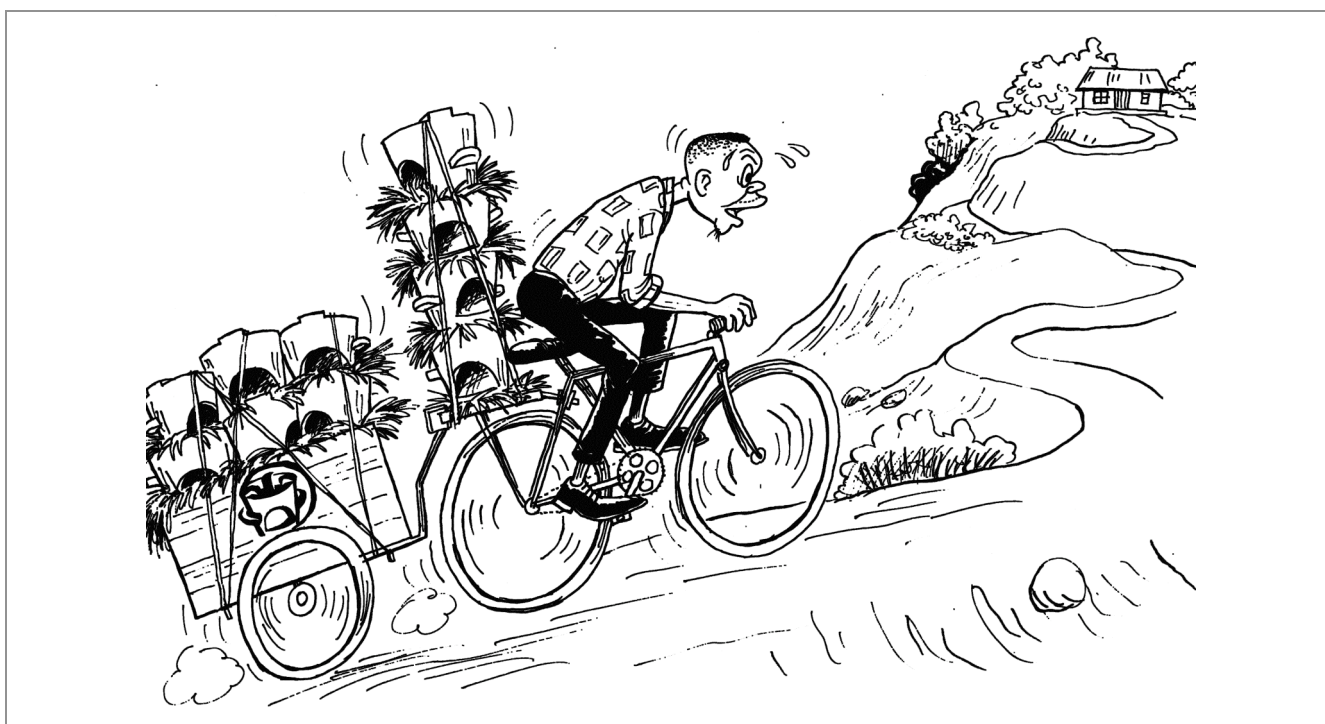

**Making the stoves reach the users is a challenge, but everybody should have access to better stoves.**

## 2.11 – Cost and price of stove

How much does a stove cost? Zero kwacha is what the end-user would love. Take care; the stove can be used as a nice stool to sit on. If the stove is not for free – the buyer has invested money in this – I should not leave it idle. I should use it. If free, make it “creatively” free. It is not the most ideal thing. The household pays the market price – but gets pigeon pea seed as part of the “grow your own firewood campaign”. Give free “promotional stoves” only to the most influential people and the opinion such as Group Village Headman or Village Chief.

Don’t get it free from producer – you will be getting the last. How much should a stove cost? Gauge the typical income for the target community. Consider the various seasons and factors that influence incomes over the year. Know how much you should mentor the production groups to sell at. Survey end-users on willingness to pay – this can be done creatively. If you were to send somebody to fetch firewood for you – how much would they charge you? If you had a product that would save such costs how much money would you be willing to pay. Related to the everyday costs. Determine a “potentially ideal” price. Back pocket idea on price.

Facilitate cost estimate with producers. Cost after they have a feel of what it takes to make a stove. List all the inputs and cost what it takes to get them in bulk. If you were to hire somebody to collect clay using an oxcart, or bicycle or if someone was to fetch for you. Do the same for water and other inputs. Charge their time as well. Charge other services as well (e.g. storage, transport etc. as applicable). Explain price should base not on their needs but what it takes to have it as an end-user. Agree on possible unit price and ask if the “do unto others” principle applies. Would they pay for that price themselves? Do this with all the production centres that are feeding the same market. Need to unify the market – we don’t want profit to be sole driver. Discuss what is a fair profit and negotiate with them. Appropriate prices are likely to vary depending on location. Price is a factor of where and how you are getting inputs and making your problem. Producer should set their own prices – after being exposed to open their eyes.

Demo stoves can be used to promote the stove. Target people in the village who have money or have money coming in soon. Try it and I will get it after 3 days. Just let me know how it compares to the 3-stone fire. Those that complain about stove prices normally are later convinced by hearing from their neighbours about positive experiences.



**The right cost will motivate producers, the right price will attract customers and the difference can motivate stove promoters.**

## CHITETZO MBAULA DRAFT GUIDELINES

### CHAPTER THREE – IMPROVED COOK STOVES AND HEALTH

#### CONTENTS

<b>3.1 - Objectives</b> .....	<b>38</b>
<b>3.2 - Background</b> .....	<b>39</b>
<b>3.3 – Chitetezo Mbaula – human energy saver</b> .....	<b>40</b>
<b>3.4 – Air Pollution: A Killer in the Kitchen</b> .....	<b>41</b>
<b>3.5 – Improved Kitchen design</b> .....	<b>42</b>
<b>3.6 – The effect of pollution on pregnant women and unborn children</b> .....	<b>43</b>
<b>3.7 – Children’s health and safety in the Kitchen</b> .....	<b>44</b>
<b>3.8 – Improving the livelihoods &amp; wellbeing of people living with HIV/AIDS</b> .....	<b>45</b>
<b>3.9 – Improving the Livelihoods of Care-Givers</b> .....	<b>47</b>

#### **3.1 - Objectives**

This chapter is intended to equip field facilitators and extension staff with information on the links between health and use of improved cook stoves and associated kitchen and firewood management practices. It serves as a guide to understanding the relationship between energy conservation and people’s health, particularly that of women, children, persons living with HIV and chronic illnesses, and their care-givers.

Using the Chitetezo Mbaula portable cook stove saves human energy and reduces emissions of smoke, which is not good for people’s health. Tips are provided throughout the manual on how air pollution can be reduced and/or avoided, and on good firewood and kitchen management practices which will contribute to energy savings.

## 3.2 - Background

Most people in Malawi depend on wood fuel for preparation of food and other activities such as preparation of herbal remedies, warming the body and warming water for bathing. Wood fuel can be a low cost, effective and relatively clean fuel when burnt in efficient stoves. However, the continued use of traditional cooking practices and inefficient stoves in closed environments leads to high exposure to indoor air pollution. Inefficient stoves use a lot of firewood and as the country grows firewood is becoming increasingly scarce and more difficult to source, with significant implications for the sick.

The available evidence suggests that the indoor air pollution from wood fuel and traditional cooking stoves may be a serious health threat, mainly to women and young children who spend a large amount of time exposed to such cooking conditions. The level of pollutants released by indoor wood fuel burning are often 10 to 20 times higher than the recommended upper limits of exposure established by the World Health Organization (WHO). Generally it is the small particulates of airborne pollution in indoor smoke that inflames the airways and lungs, weakening the immune response and reducing the oxygen-carrying capacity of the blood, which is important for our health. The WHO ranks lower respiratory infection in second place for the top ten causes of death for all ages in Malawi.

For people living with chronic illness avoiding such opportunistic infections can be helped by reducing exposure to smoke. Also by being able to save time and human energy by using less fuel is a real benefit for the sick. Carers that provide support to the sick in the form of activities like cooking, feeding, bathing, carrying the person from place to place, turning the person, and providing spiritual and psychological support can benefit from being less distracted from his or her normal productive activities such as farming, business or employment activities. By using wood saving technologies and techniques, caregivers, chronically ill persons and PLWA can save time, money and energy otherwise spent collecting and purchasing wood fuel for cooking, and put these savings toward better caring for themselves and others. Hence the transition to improved cook stoves such as the Chitetezo Mbaula, and improving kitchen practices such as better ventilation can mitigate indoor air pollution and can translate into improved health and positive economic effects, as well as have environmental and human welfare benefits.



**Sick people should be kept away from hazardous conditions such as indoor smoke.**

### 3.3 – Chitetezo Mbaula – human energy saver

The Chitetezo Mbaula is an energy saving portable clay stove. The energy it saves is wood energy and also for human used in the entire cooking process, starting from less time and effort spent collecting wood for cooking, to the energy or effort conserved while actually cooking.

Benefits of the energy saving Chitetezo Mbaula include firewood savings, smoke reduction, faster cooking, less time spent in kitchen, sheltered safer fire, less heat exposure, small twigs and alternative fuel sources such as pigeon pea stalks can be used to generate enough heat for cooking. Alternative fuel sources such as pigeon pea stalks, agro-forestry species also can improve soil fertility leading to more food production and less expenditure for fertilizer, which in turn can lead to more food (relish) or cash and fuel for cooking.

The benefits of using the Chitetezo Mbaula are enhanced by good firewood and kitchen management techniques such as using dry firewood, keeping a lid on the pot while cooking, soaking legumes such as beans and peas before cooking, tenderizing meat before cooking, and using only as much water for cooking as is necessary.





### 3.4 – Air Pollution: A Killer in the Kitchen

Smoke is a product of incomplete combustion. When wood fuel is inefficiently burned on the three stone fire, hundreds of pollutants – visible (like the black soot which covers the walls and ceiling of the kitchen) and invisible – are released into the air. The invisible pollutants are the most dangerous because they can get deep into the lungs and result in severe illness. These air polluting particles are especially harmful for the women and children who spend long periods in the kitchen preparing meals and hot water for their families.

#### The health consequences of such exposure to indoor air pollution include:

- Severe lower respiratory tract infections, asthma and upper airway cancers
- Cardiovascular disease
- Low birth weight
- Peri-natal mortality (stillbirths and deaths during the first week of life)

#### Air pollution in the kitchen is caused by:

- Inefficient cooking technologies such as the three stone fire
- Inadequate kitchen ventilation
- Poor firewood management

#### Air Pollution in the kitchen can be significantly reduced through:

- Use of improved cooking technologies such as the Chitetezo Mbaula
- Ensuring there is adequate ventilation in the kitchen
- Splitting firewood and using only dry firewood (sun-dried or on racks above cooking area to remove moisture)



People get used to smoke but it is dangerous for our health.

### 3.5 – Improved Kitchen design

The kitchen is at the heart of the home. All too often, however, it is a smokey place with various safety and health hazards that pose dangers to cooks and children. It is not difficult to improve basic design features of kitchens to minimise smoke, to reduce risks and to make the cooking experience more comfortable and healthy.

The Chitetzo Mbaula reduces the amount of smoke produced during cooking by improving the burning of the fire so that there is less incomplete combustion. Also with improved heat transfer not as much wood is used for cooking or heating and this also reduces smoke. However, some smoke will still be emitted and it is important that this smoke is encouraged to leave the kitchen in a way that reduces exposure to smoke. A mono-pitched roof, low walls, walls with air-spaces or other outlets for smoke to escape allow the air to flow in and out of the kitchen during cooking and help to circulate air thereby reducing the amount of polluted air in the kitchen. As a rule, you should be able to have a clear view out of the kitchen while cooking.

It is also important to design the kitchen so that fuel can be stored and dried on firewood racks, possibly above the stove to take advantage of the rising heat from the fire. A simple sand pit can also be used to extinguish flames from partially burnt wood after cooking. This saves wood and reduces smoke after cooking.

A fireless cooker or food-warmer is a low-cost but effective way of saving firewood and of conserving nutrition by putting a boiling pot of food with a lid into a well insulated “warmer” where the pot can continue cooking using only residual or insulated heat. The warmer can be made from a basket or custom-built mud container lined with insulating materials such as banana leaves or straw and a tightly fitted lid, to conserve heat. The fireless cooker should be built to fit the pot with which it will be used. Fireless cookers are best suited for cooking legumes and grains which cook slowly with low heat. Although cooking time is slower than usual, the fireless cooker does not need to be tended to, so cooks are free to use their time elsewhere.

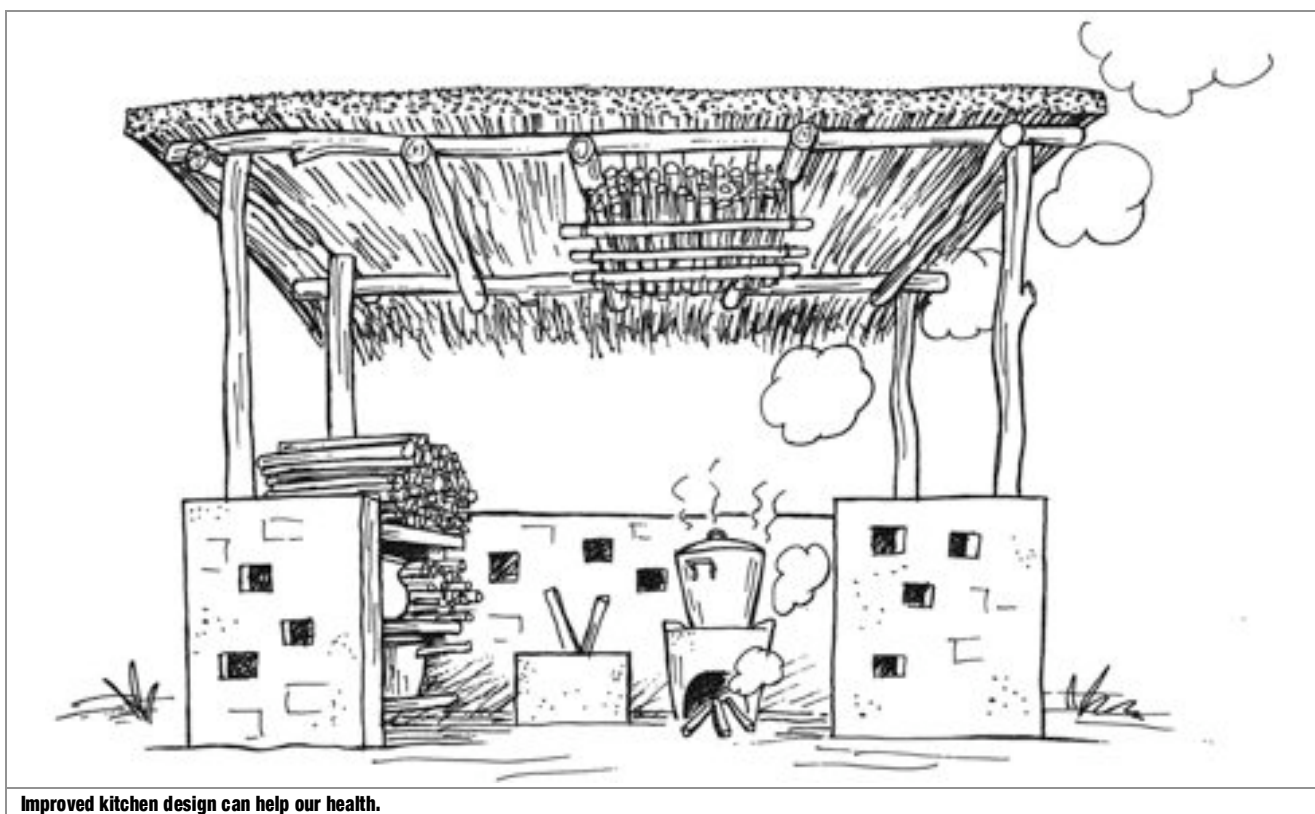

Improved kitchen design can help our health.

### 3.6 – The effect of pollution on pregnant women and unborn children

Cooking brings women together to exchange stories with one another about their children, their husbands and life in general. The most common way of cooking in Malawi involves women squatting by three stone fires, bringing water to their eyes as the wind carries the emitted smoke, and sending smoke and air polluting particles directly into their nostrils as they prepare meals for their families.

In addition to the numerous effects of such air pollution to women and children in general, pregnant women are at risk for spontaneous abortion, and put their unborn children at risk from the following:

- Low birth weight,
- Pre-maturity, and
- Heart defects at birth.

Using a Chitetezo Mbaula which emits less soot and smoke, having a well ventilated kitchen and using dry firewood can significantly help reduce the air pollution to which women – especially pregnant women – are exposed in the kitchen, and reduce the risk of harming unborn children.



**Scientists predict that smoke is particularly dangerous for unborn children.**

### 3.7 – Children’s health and safety in the Kitchen

Open style cooking such as on a traditional three stone fire is particularly dangerous for children who accompany and help their mothers and female relatives in the kitchen; in particular, young children who are slung over their mothers’ backs while their mothers squat over the fire.

Safety risks for children in the kitchen include the danger of receiving accidental burns from the open flame or of being scalded by a pot falling off the 3-stone fires. Also, children are particularly vulnerable, given their less mature immune systems, of developing asthma, reduced lung function, wheezing, severe cough and bronchitis, and school absenteeisms due to respiratory illnesses.

Children can be protected from receiving accidental burns from open flames by using a Chitetezo Mbaula which:

- is a stable stove and the risks of tipping are minimal,
- the burning fuel is more contained compared to a three stone fire,
- the flames are more sheltered around the cooking pot and fuel chamber,

The Chitetezo Mbaula produces less smoke and also emits less soot and air pollutants. In addition to using a Chitetezo Mbaula, by using dry firewood and having a well ventilated kitchen, children can be protected from indoor air pollutants. Ideally mothers or carers should ask a member of the household, who is not cooking, to keep their young children away from smoke outside of the kitchen.



Children should be kept away from the cooking place to avoid accidents and exposure to smoke.

### 3.8 – Improving the livelihoods & wellbeing of people living with HIV/AIDS

One of the steps toward making progress in responding to the HIV and AIDs pandemic is enabling PLHIV and others affected to conserve enough energy to keep going.

Energy is especially needed for care and support activities like:

- Cooking meals
- Boiling water for drinking
- Cooking herbal remedies, hot compresses
- Heating water for bathing
- Sterilising utensils for patients
- Warmth

HIV and AIDS pandemic causes PLHIV and affected households to become labour constrained. Use of a Chitetezo Mbaula can help PLWHIV to conserve their energy because the Chitetezo Mbaula uses less firewood than the traditional open fire, so PLWHIV can use the same quantity of firewood for a longer time, and will therefore spend less time, money and energy going out to collect or purchase firewood.

We can save energy by using improved technologies such as stoves and fireless cookers *and* by adopting improved practices such as keeping a lid on the pot, soaking legumes, using less water, cooking for less time etc.

In addition to conserving energy, a person living with HIV can enhance his/her livelihood and general wellbeing by seeking early medical advice, having a desire to be productive, having a good income, getting support from others, having good ventilation (reduce air pollution), avoiding stress and worries, avoiding infections, having good hygiene and sanitation, physical fitness and good nutrition.

It is important for people, particularly those living with illnesses, to avoid physical stress, but maintain physical fitness, which can be made easier by using a Chitetzo Mbaula. The sick should avoid carrying heavy loads and walking long distances and instead collect twigs with little effort but good for exercise. Avoid too much heat and stress from cooking. Get adequate rest, spend less time on cooking and collecting firewood.



Improved cook stoves such as Chitetezo Mbaula can use easy to get firewood such as twigs, which makes sick people's life easier.

Improved kitchen practices and the use of a Chitetezo Mbaula can also play a part in improving nutrition by having more frequent meals and timely meals, with less cooking time. Warm, soft and palatable food and steamed or boiled food, that use less frying can help to preserve nutrients. Locally available food can be used with safe and clean drinking water to provide adequate small amounts of a variety of food from the six food groups.

People living with HIV/AIDS have higher nutritional needs than most people as their immune systems need to work harder to prevent further disease and infection. Healthy foods for people living with HIV/AIDS include:

Fresh raw vegetables and fruits, sprouts, raw nuts and raw seeds which contain enzymes that help in the breakdown of foods into nutrients.	Yellow and orange vegetables and fruits, milk, garlic, egg yolk and liver, vegetable oils, nuts and seeds which contain antioxidants that block unstable chemicals (free radicals) in the body.
Garlic, onions and milk products, which promote the growth of friendly flora – the bacteria that prevent infections in the digestive tract.	Garlic, yoghurt, lemon, fermented foods, fruits, vegetables and sprouts which are power foods rich in health-giving nutrients.
Spice teas – ginger tea, garlic tea, lemon grass tea which are rich in vitamins and have good medical properties.	Mashed foods such as orange-fleshed sweet potato, cassava and Irish potatoes. These could be mixed with ginger or garlic.

Healthy eating for PLWA can bring many benefits including (1) improves digestion and keeps body weight stable, (2) replaces lost nutrients, (3) prevents opportunistic infections, (4) improves wound healing, (5) improves recovery from infections, (6) enables the patient’s body to better absorb medication and treatment, (7) increases strength and (8) improves general well being

Prevention of infections is very important for PLWA and can be done by eating diets rich in the proteins, vitamins and minerals necessary for the body’s immune system to function well in fighting against disease and infection. Infection can also be avoided through improved nutrition and hygiene.



**People who are sick need a well balanced diet.**

### 3.9 – Improving the Livelihoods of Care-Givers

The role of care-givers in supporting PLWA and chronic illnesses cannot be underestimated. A care-giver can yield the following time and livelihood benefits through use of the energy saving Chitetezo Mbaula:

- Less time spent collecting firewood and cooking
- Mobile feeding
- Less stress and burn out
- More time to care for themselves other family members
- Less exposure to heat and smoke
- More money for food and other goods
- Reduced time conflicts
- More time to mobilise resources for his/her household



Care-givers have time to do other family chores when they are not required to collect as much firewood.

## CHITETezo MBAULA DRAFT GUIDELINES

### CHAPTER FOUR – IMPROVED COOK STOVES AND NUTRITION

#### CONTENTS

4.1 - Objectives .....	48
4.2 - Introduction .....	49
4.3 – Chitetezo Mbaula – energy saving and nutrition friendly practices.....	50
4.4 – The nutrients we need every day .....	51
4.5 – Cooking tips for the six food groups.....	52
4.6 – Food and nutrition for growing children.....	54
4.7 – Healthy kitchen gardens .....	55

#### 4.1 - Objectives

This chapter serves as a guideline on how to cook nutritious meals whilst saving firewood by using the Chitetezo Mbaula. The essential nutrients and different food groups necessary for children and adults are discussed, with local examples of their sources. There is also a special focus on how the various food groups can be prepared and consumed to maximise their nutritional values.

Using the energy saving Chitetezo Mbaula for preparation of nutritious meals will save firewood – and reduce the time and money spent collecting and purchasing it, giving the household more capacity to grow or buy food and essential goods – and preserve our natural environment.

Firewood saving techniques and tips are highlighted throughout this booklet including:

- Basic wood and kitchen management techniques,
- preparing the different types of food for cooking,
- how to manage the fire while the food is being cooked, and
- making use of the hot stove after cooking is completed
- how to establish homestead gardens



## 4.2 - Introduction

We all need food to live. Our bodies are similar to a car– we need to have fuel so that we work properly and stay healthy. We get this fuel from chemicals called nutrients found in food and drinks. Nutrients are found in different amounts and combinations in different foods and drinks. Therefore, it is very important to have a healthy diet.

A healthy diet means:

- Eating a **variety** of foods every day, and foods of all colours;
- A good **balance** of foods – eating the right amounts of different foods; and
- **Moderation** – being careful not to eat too much of any one type of food.

If we eat too much or too little of any type of food, our bodies will not be able to grow, work or repair itself well. The right amount of food we need depends on many things such as our age, sex, body size, level of activity, and if we are living with any particular illness such as HIV/AIDS. There are many different types of food, each containing different nutrients, which we will discuss later. The body also needs water, which is not a nutrient, but it is important we keep our water levels topped up – just like a car.

To prepare many of the foods that our bodies benefit from, we require heat. In the context of a Malawian village, this heat is generated by burning firewood. With the increasing pressure on Malawi's wood resources, it is important that we cook our food on an energy saving stove. One of such stoves is the Chitetezo Mbaula which, if properly used and if good kitchen management practices are applied, can help us prepare healthy meals.



Once the beans have been boiled the pot is put in a fireless cooker and the Chitetezo Mbaula can be used for cooking nsima or other staple foods.

### 4.3 – Chitetezo Mbaula – energy saving and nutrition friendly practices

The Chitetezo Mbaula is a friend in the kitchen to secure the food necessary for health and growth. Good nutrition involves frequent and timely meals. Food preparation is very important for nutrition. Warm, soft and palatable food can be prepared by boiling or steaming. To reserve nutrients it is important not to fry too much. Use fresh locally produced ingredient rather than processed ingredients, as it is healthier. Always use clean and safe water.

By employing some of the following practices wood can be saved, work can be less and nutrition can be conserved:

- Cook meals for all members of the household at the same time;
- Prepare all the food being cooked before lighting the fire;
- Keep all utensils needed for cooking nearby and ready for use;
- Cook together foods which will be mixed after cooking;
- Cook with the smallest amount of liquid possible – just enough to get steamed;
- Use dry firewood – Firewood can be left out in the sun to dry in hot weather, or kept indoors in the roof space or on a rack above the fire in wet weather. It can also be stacked against walls or kept in a separate storage building;
- Use pot lids while cooking to retain heat and keep out dust and ash,
- Cook all dishes for the meal one after the other so the stove does not get cold;
- Do not overcook food;
- Put the fire out as soon as cooking is finished. Unburned pieces of wood can be removed after cooking and extinguishing in sand so that there is little smoke and the wood can be used to cook another meal;
- Make use of the hot stove for heating water after the fire is put out.
- More tips on how to use the energy saving stove to prepare healthy meals will be discussed in the chapters that follow.

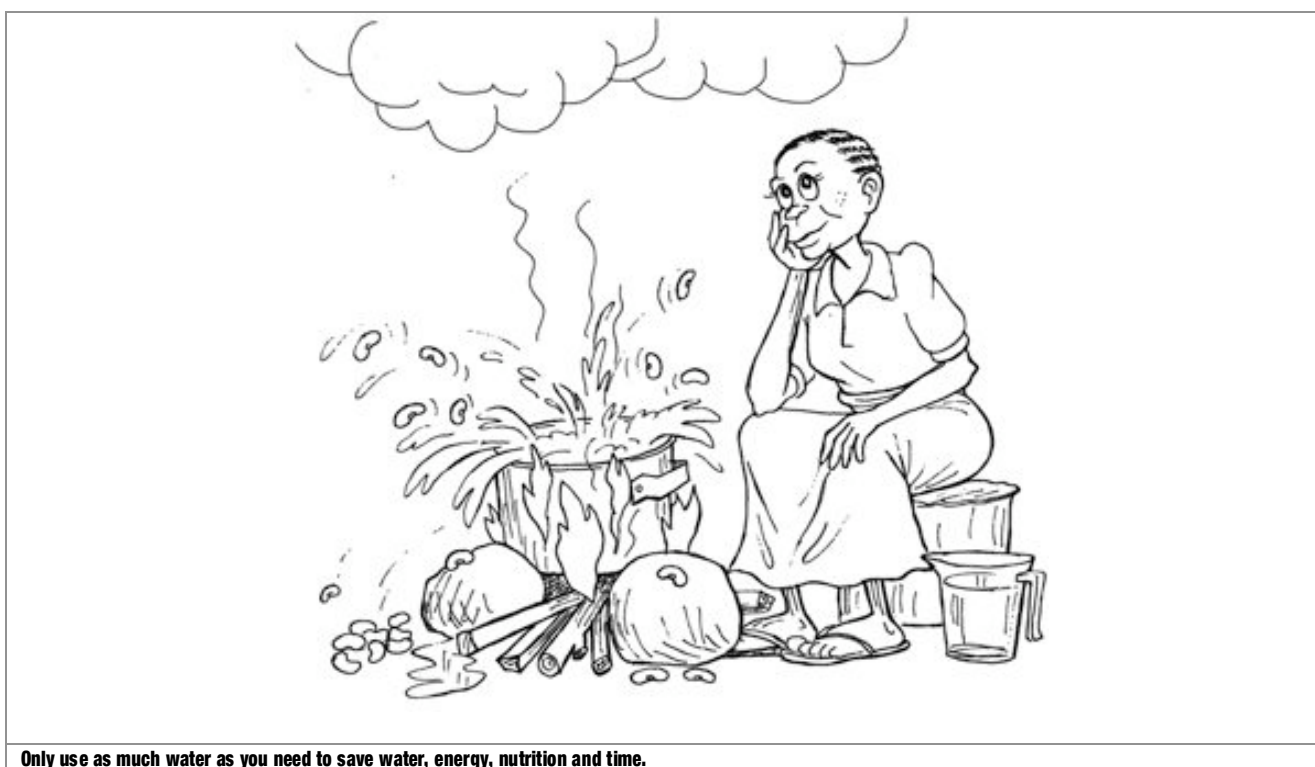

**Only use as much water as you need to save water, energy, nutrition and time.**

## 4.4 – The nutrients we need every day

Carbohydrates – to give us energy for everyday activities like walking, working and studying. We should be careful not to eat more carbohydrates than we need because excess carbohydrates are stored in our bodies as fat. *Fibre* is a type of carbohydrate, which is important for good bowel movements, reducing cholesterol, and lowering the risk of diabetes and heart disease.

Proteins – to help us grow, to repair damaged tissues in our bodies, and to help us make anti-bodies to fight off infections. Our bodies cannot store excess proteins, so it is important that we include them in our meals every day.

Vitamins are essential for normal growth and development of our skin, bones and muscles (especially in children to prevent disease), and also important for good eyesight and a good immune system. If we are severely lacking vitamins, we will be more likely to become sick and could even become blind. Our bodies cannot store vitamins so it is very important that we eat foods containing vitamins every day.

Minerals – used for many essential body functions such as regulating our heartbeat, moving our muscles, maintaining our bones and teeth, maintaining our nervous system, and producing red blood cells so that our blood can carry the oxygen we breathe in. Lack of certain minerals like iron can cause us to become sick, for example, get anaemia. We only need a small amount of minerals since eating too many minerals can be bad for us.

Fats & Oils give us energy for growth. If we do not have enough fats, our bodies cannot make use of the vitamins and minerals we eat. It is also important that we do not eat too many fatty foods.



Overcooking food is wasteful of food, nutrition and firewood.

## 4.5 – Cooking tips for the six food groups

### Staples

Staples contain mostly carbohydrates, but are also a source of fibre and vitamins and minerals depending on how they are processed. For example, whole grain flour is much more nutritious than the more processed white maize flour. Needed in large quantities so that we have energy for daily activities. Include foods such as nsima and other maize products, bread, oats, rice, sweet or Irish potatoes, cassavas and starchy fruits like bananas.

- Staples such as potatoes and cassavas can be cut into small pieces and boiled (rather than fried) on the Chitetezo Mbaula in a pot with a lid on so that they will cook faster and use less firewood.
- Nsima and staples which are being boiled can be cooked last on the Chitetezo Mbaula so that after the water comes to a boil, sticks of firewood can be removed as the food can be cooked with less heat.

### Animal Meat & Other Animal Products

Good sources of protein, Vitamin B, minerals such as calcium, and fats. Meat can be replaced by larger quantities of legumes and nuts. Include foods such as eggs, milk, fish, goat, chicken and insects.

- Tenderizing meat and fish before cooking on the Chitetezo Mbaula allows you to save time and firewood.
- Cutting meat into smaller pieces for cooking also helps you to cook faster and use less firewood.
- Keep the lid on your pot to retain heat, save time and firewood while cooking on Chitetezo Mbaula.

### Legumes & Nuts

Legumes and nuts are very good sources of proteins, and also a source of carbohydrates and fats (nuts). They are needed in larger quantities for our body's growth and repair. Include foods such as ground beans, groundnuts, cowpeas, pigeonpeas, green peas, soya beans, kidney beans and lentils. Legumes and nuts if eaten in adequate quantities can be eaten instead of animal meat and fish.

- Peas and beans will cook faster and use less firewood on the Chitetezo Mbaula if soaked for several hours before being cooked. When boiling water, you can save time and firewood by using a pot lid to retain heat.
- Use as little water as possible for cooking beans to save water, time and firewood on your Chitetezo Mbaula.

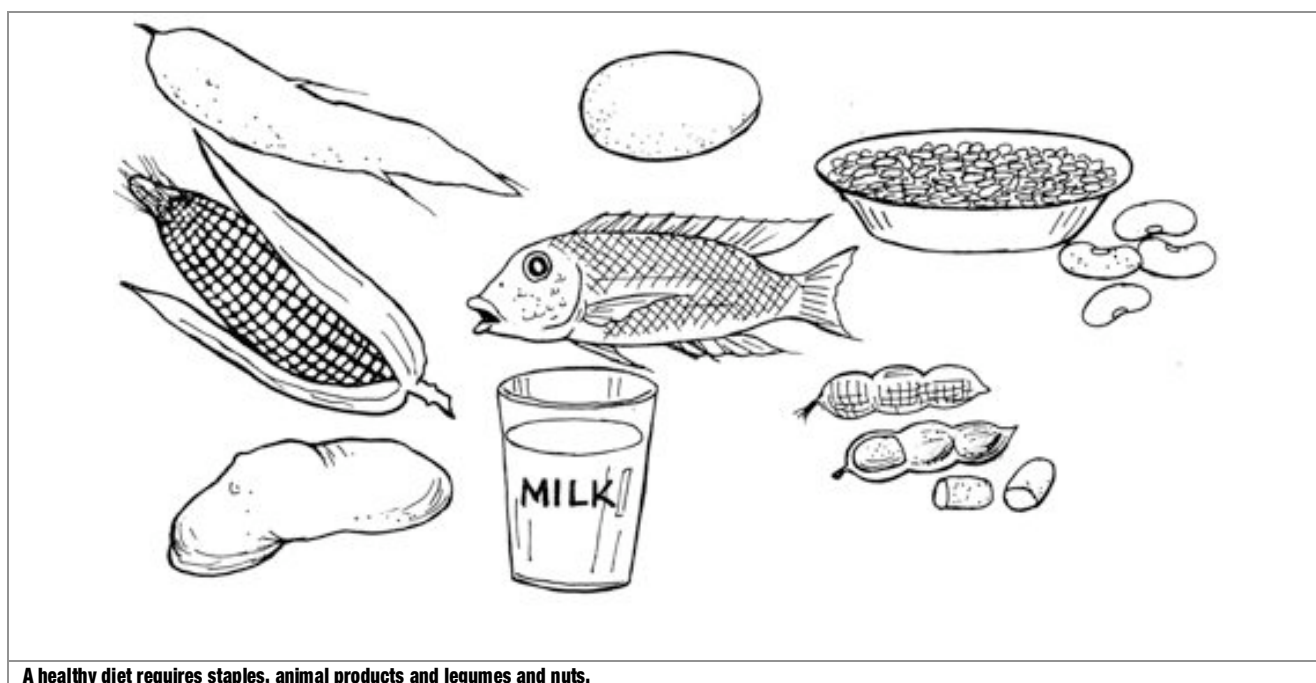

A healthy diet requires staples, animal products and legumes and nuts.

## Vegetables

Vegetables particularly good sources of Vitamins A and C; minerals such as folate, iron and magnesium; and fibre. Needed in quantities almost equal to staples. Can be dark, green leafy vegetables, red or orange, or pale coloured and include mustard, spinach, lettuce, cabbages, squash, carrots, pumpkin, red peppers, tomatoes, avocados, beet, cauliflower, broccoli, cucumber, eggplant, mushroom, onions and okra. Not all vegetables need to be cooked. Carrots, tomatoes, lettuce and cucumber are best eaten uncooked. Many vegetables are also best eaten steamed instead of fried. Some vegetables are considered to be water soluble, and therefore lose their nutritional value when cooked to the point where they produce liquid.

- In order to preserve the nutrients found in vegetables, a lot of heat is not necessary when cooking vegetables. Therefore, when cooking with your Chitetezo Mbaulta, you may use a pot with a lid and remove a stick of firewood so that the vegetables can simmer at a lower heat.

## Fats & Oils

The main nutrient is fats. Fats are contained in most animal and plant produce, and oils can be obtained from pressed nuts and seeds from sunflowers, vegetables and other produce. Animal fats can also be used for oils. Fats and oils are only needed in small quantities.

## Fruits

Fruit are also good sources of Vitamins A and C, minerals such as potassium, and fibre. More is better, so choose a variety of fruits of different colours. Nutritious fruit include mangoes, guavas, bananas, oranges, papaya, pineapple, watermelon, strawberries and tangerines. Fruit is best eaten fresh and does not need to be cooked.

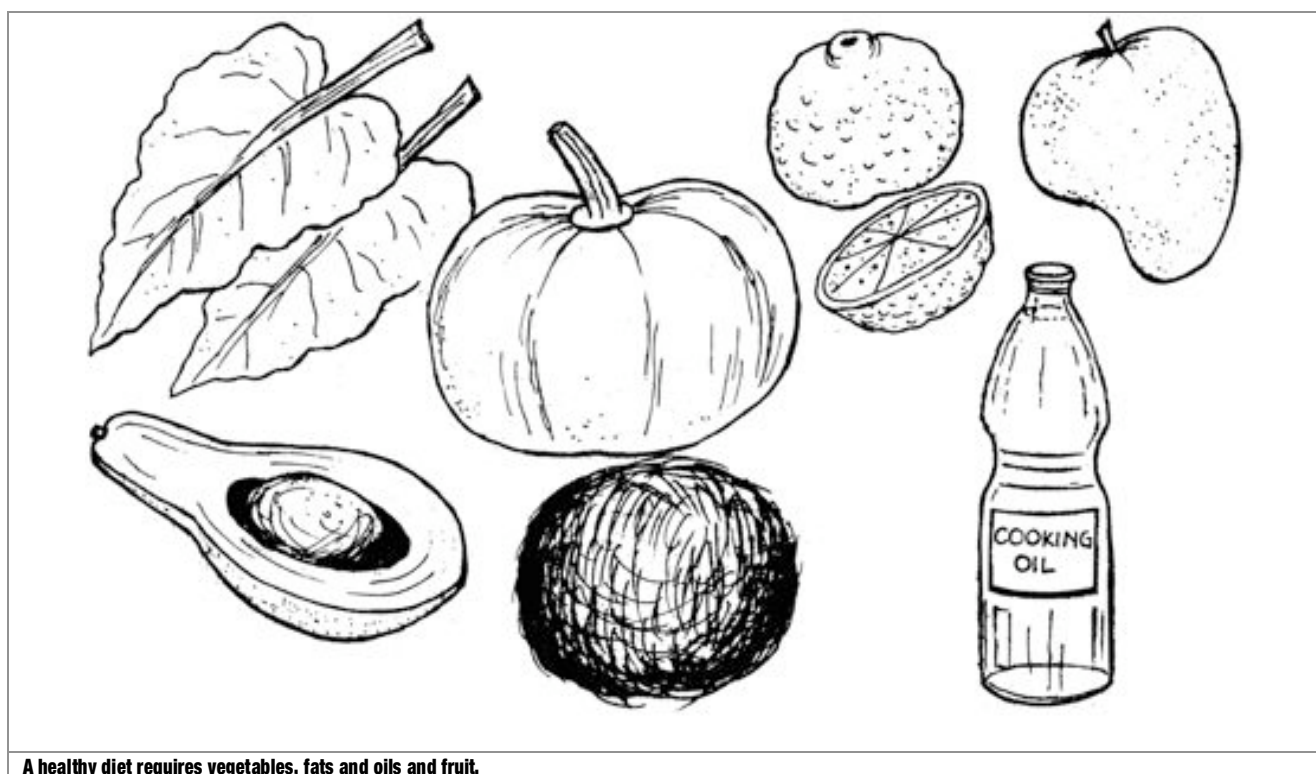

A healthy diet requires vegetables, fats and oils and fruit.

## 4.6 – Food and nutrition for growing children

A balanced diet is essential for everyone, but growing children, particularly children under 5 years and adolescents require more nutrients to support their healthy growth and development. Lack of sufficient nutrients can result in children with stunted growth. Having a healthy balanced diet will also allow your child to concentrate more in school and learn better.

Special care must be taken to include both calcium and iron in your child's diet. Calcium, best obtained from milk, is a mineral essential for healthy bone development. Green leafy vegetables and oranges are also good sources of calcium. Iron is essential to keep the red blood cells healthy, and can be found in red meats and beans.

It is recommended that you breastfeed your child for at least the first 6 months of his/her life. Breastfeeding can be supplemented with smaller meals during the day such as porridge which is not too thick that the baby cannot eat much, but not too thin that the baby does not get enough energy and nutrients.

That breakfast is the most important meal of the day. If we skip breakfast we will miss out on a lot of essential vitamins and minerals which will help us to be productive throughout the day. Try having an egg, fruit or cereal with milk.

Staples are not enough. Ensure that your child has enough protein and eats lots of fresh fruits, vegetables, legumes and nuts in his/her diet. Minimise the amount of processing to conserve nutrients. Eat whole grains and seeds such as mgaiwa, whole wheat bread, and unpolished rice.



## 4.7 – Healthy kitchen gardens

Kitchen gardens encourage households to produce a wide range of high value indigenous vegetables behind their kitchens often irrigated with kitchen wastewater. There are a wide range of indigenous vegetables that have been proven to have high nutritive values such as amaranthus (bonongwe), cat whiskers (luni), denje and cowpeas. Households are encouraged to produce as many of these vegetables as they can, and to recycle seeds and pass on to others.

Healthy kitchen gardens can be planted around the house in spaces that are not productively used. Make a long list of different healthy foods that your household requires and that you can grow around your homestead. For each food group identify foods that are locally available, taking into account the season in which the foods are available. The list should include fruit trees, herbs and spices, vegetables and medicinal plants.

Work on improving the soil around the homestead by designing a way that you continuously gather organic wastes and make compost manure, which will be applied to the production sites of health foods. Ash from the Chitetezo Mbaula can also be used as an input for the manure. Plant your food crops and medicinal plants using a lot of organic matter. Keep on weeding, watering and adding more organic matter as need arises.

Design structures – access paths, road, flower beds, kitchen garden and fruit tree sites, lawn grass sites etc, by deciding on what will be grown where. Seek advice from agriculture extension workers in your area if you are not sure.

It is important to develop your health garden during the rainy season when there is plentiful supply of water and most of the perennial plants can be established without many problems. In the dry season, wastewater can be used to maintain the plants that require irrigation.

As the plants get established any time you need any of the plants to prepare specific recipes you obtain them from your garden.



**Help your health and save money by growing many different foods around the homestead.**

## CHITETEO MBAULA DRAFT GUIDELINES

### CHAPTER FIVE – IMPROVED COOK STOVES AND FUEL

#### CONTENTS

5.1 - Objectives .....	56
5.2 – Introduction .....	57
5.3 – Managing firewood to conserve fuel .....	58
5.4 – Be energy secure - grow your own fuel.....	59
5.5 – Grow your own fuel - conservation agriculture with trees.....	60
5.6 – Grow your own fuel - agro-forestry .....	61

#### 5.1 - Objectives

This chapter serves as guideline on how to conserve, obtain and efficiently use wood fuel in cooking and provision of heat. Conservation, efficiency and access to wood fuel for cooking are all topical issues given the increasing scarcity and expense involved in obtaining wood fuel.

The main focus in this chapter will be:

- Achieving efficiency and conserving wood fuel through use of improved cook stoves, such as the Chitetezo Mbaula, that use less firewood than the traditional three stone fire;
- Achieving efficiency and conserving wood fuel through good firewood and kitchen management techniques, and
- Improving availability and access to wood fuel through climate smart agricultural techniques such as conservation agriculture and agroforestry, which are integrated food and energy systems.



## 5.2 – Introduction

Wood fuel for cooking is a daily necessity for almost all Malawians. However, in recent years, deforestation and competition between land for forest, food production and housing have resulted in wood fuel becoming scarcer and more difficult to source. This puts more pressure on women and children who tend to do more of the collection of wood fuel, and becomes a greater strain on households. Households may not be able to source their preferred wood fuel, they may have to travel increasingly longer distances to collect wood, or in the case that they purchase wood may have to pay higher prices and dedicate more of their income to buying wood fuel.

Improved cook stoves, such as the Chitetezo Mbaula, can provide relief to such households. By burning wood more efficiently, this stove can help households to make their wood last longer, meaning less time and labour spent collecting wood, and less money spent each month purchasing wood for cooking and heating. These savings can be enhanced by using other energy conserving practices such as only using split and dried firewood and by better cooking practices such as keeping a lid on the pot, only boiling the amount of water that you need, soaking beans overnight and so on.

In addition, climate smart agricultural practices such as conservation agriculture and agroforestry facilitate growing crops which can be used for both food and fuel can assist households in having their own supply of wood fuel. Conservation agriculture, agroforestry and food and fuel crops are presented as approaches that can sustain energy access and security at the household level.



**Agro-forestry can help provide the food and energy needs of a family.**

### 5.3 – Managing firewood to conserve fuel

To make the most of improved cook stove such as the Chitetezo Mbaula it is very important that fuel be managed so that is easy to access when it is needed, that it is dry and in pieces small enough to fit into the stove, and that is from a sustainable supply.

Most people in rural areas of Malawi collect their fuel wood from the forests. It is important that the wood is wisely collected to make sure that there will be more fuel for the future. Trees can be coppiced in a way to help future supply and it is also important to plant new trees for fuel and other uses.

Ensure that your firewood is dry before being used for cooking. Burning wet wood produces smoke and produces less heat. Firewood can be dried in the sun during dry weather, or on drying racks or in roof-spaces above the cooking site in the kitchen during wet weather. Firewood can also become dry if left standing on the sides of walls inside the kitchen or storage room.

Only use as much firewood as you need. One simple meal can usually be prepared with between three and six sticks of firewood. It is best to start with three sticks and remove one as soon as the food is boiling, so that the food will simmer until cooked. This method both conserves firewood and results in the food being more healthy and nutritious.

Put the fire out as soon as cooking is finished. Unburned pieces of wood can be removed after cooking and extinguished in sand so that there is little smoke and the wood can be used to cook another meal. Once the fire is put out there is still heat retained in the stove and this can be used for heating water.



Planting trees and looking after them can make people happy as it will help relieve the pressure on natural resources of the village.

## 5.4 – Be energy secure - grow your own fuel

For almost everybody in rural Malawi wood is the main, if not only, source of energy for cooking and heating. Without wood people cannot eat cooked meals. Wood is a valuable raw material. Wood is life. When we cut more wood than we grow the resource can be exhausted. But when we grow enough to meet our needs we can have easy access to fuel and we can have a secure source of energy. We can grow the specie of tree that we specially like for firewood and mix them in with other plants and trees. This can allow the whole family to benefit from not having to spend much time and effort in collecting wood. If there is a sick person in the household they do not have to travel far to get access to wood.

If we can grow more wood than we need we can sell what is left over to generate income and meet the needs of others. It is possible to have our own “energy forests” and set up small energy businesses to sell wood for energy for other especially to those in the towns and cities where it is not easy to get good firewood.

Trees for fuel can also be included in our garden as part of agroforestry and conservation agriculture.



Apart from providing manure, trees such as *Gliricidia* can ease energy pressure for farmers.

## 5.5 – Grow your own fuel - conservation agriculture with trees

Conservation agriculture is a type of farming that is becoming more popular in Malawi as people experience the benefits for themselves. There are three main elements of conservation agriculture, namely: (1) Continuous minimal soil disturbance– conservation farmers don't plough the land up; they make small holes year after year in the same places which helps water permeate the soil and promotes the growth of beneficial natural tillers like earthworms, (2) Maintaining good organic soil cover – Instead of sweeping the land clean and removing the natural residues and burning them, conservation farming teaches us to save this valuable mulch. Covering the land stops evaporation, gives nutrients back to the soil, and protects the ground from the occasional torrential rain. (3) Achieving the best association of crops – Intercropping Cereal crops with grain (food) legumes like pigeon pea, beans or groundnuts, to enrich the soil and make it more productive. The pigeonpea is an example of food and energy crop that can be intercropped with maize, sorghum or millet and can be sold as a cash crop, which currently fetches high prices. Other non-food leguminous shrubs (e.g. *Tephrosia*, *Sesbania*) and trees (e.g. *Gliricidia*, *Faidherbia*, *Acacia*) can also be intercropped with cereals. The stalks of pigeonpea and *Tephrosia* that grow in less than a year can be dried and used as a fuel. Using pigeon pea or *Tephrosia* stalk as a fuel is convenient as it does not have to be split as it is already in small pieces. In addition to providing fuel, shrubs and trees in conservation agriculture protects the soil from erosion, diversifies the production system and ultimately enhances the productivity of the land. These legumes improve soil fertility by fixing nitrogen, adding organic matter and recycling nutrients in the soils. Leaves of some of the trees can also be used for animal fodder.

These practices are natural cost saving alternatives to some of the most expensive farming inputs (such as fertilisers), which are difficult to obtain or simply beyond the reach of some small-scale farmers who are struggling to produce food. Nothing is wasted from the previous crop as it is used for organic soil cover.

Good application of these techniques can result in sustained higher yields compared to conventional methods, less expenditure on farming inputs, leading to more viable farming. Substantial amounts of wood can be produced by shrubs and trees. In addition, stalks and cobs saved can also be used as biomass fuels for cooking. With a Chitetezo Mbaula and the fuels from conservation farming a household can meet all their energy needs.



Conservation agriculture can reduce the impact of shortage of food and pressure on natural resources.

## 5.6 – Grow your own fuel - agro-forestry

Another similar approach to farming is agroforestry where trees and other woody species of plants are planted as part of a farming system. Agroforestry normally requires that good planning goes into the design of the farm so that various crops, plants and trees can live together in such a way that they help each other. Some trees may help the fertility or make-up of the soils. These are called fertilizer trees. Others provide nutrient-rich fruits and animal fodder, while other may help to provide shade or ground cover, medicine or fuel. Trees may be planted on farmland in a variety of configurations, and this normally results in having very diverse farm where there are many species in a very small space. This approach can mean that the farming household does not rely on one or two crops or sources of income but may have many different sources of food and energy at different times of the year. Similar to conservation agriculture, agroforestry can lead to less expense on fertiliser and pesticides, greater independence and food and fuel security.

Agroforestry trees for fire wood production may be planted as improved fallows, scattered planting, boundary planting, contour planting and woodlots. Improved fallows involve planting fertilizer trees and shrubs such as *Tephrosia*, *Sesbania*, *Gliricidia* and *Acacia* in rotation with crops. Trees may also be planted scattered on farmland as part of the complex agricultural crop production. In Malawi this usually involves native tree species such as *Faidherbia*, *Philostigma thoningi* and *Markhamia lutea* on crop land. Boundary planting involves growing trees along boundaries and in interstitial sites. This is appropriate where trees are the dominant means of boundary demarcation, or where lines of trees serve as windbreaks. Contour planting involves growing trees in closely spaced lines (usually 1 m x 10 m) across a slope in hilly areas with high rainfall and easily eroded soils. Blocks of trees may be specifically planted for fire wood and timber production in a pure stand on arable or degraded land, and this is called woodlot. The best system for this is a coppice regime, which involves harvesting poorly formed trees for firewood and leaving better formed trees to grow on for timber. This may also involve rotational woodlots of four to five years where land size is limiting and farmers can crop the land after clear felling the trees. *Per capita* firewood consumption for an average family of six is estimated at about 10 kg per week. Based on this estimate, wood yields of rotational woodlot would be sufficient to meet the household fuelwood demands. Such high wood yields exemplify the significance and potential of agroforestry systems in meeting local firewood demands, as well as conserving natural forests that currently serve as the main local source of fuelwood.



It is not always good to clear forests as some crops can benefit from some tree species.

Some shrubs and trees species that can meet the household's wood fuel needs for cooking and heating on a Chitetezo Mbaula

Species	How to include in farming system	Other benefits
Pigeon pea - Nandolo	Interplant with maize (undersowing) or grow as improved fallow	Food, soil fertility
<i>Tephrosia volgeii</i> - Mthuthu		Soil fertility improvements, pesticide
<i>Sesbania sesban</i> - Jelejele		Soil fertility improvements
<i>Sena spectabilis</i> – Keshya wa Maluwa	Boundary planting, homestead woodlots	Soil fertility improvement, construction materials,
<i>Sena siamea</i> – Keshya wa Milimo	Boundary planting, block planted homestead woodlots	
<i>Gliricidia sepium</i>	Interplant with maize, boundary planting	Soil fertility improvement
<i>Acaci polycantha</i> - Mthethe	Boundary planting, block planting as woodlot	Fodder, soil fertility, construction materials,
<i>Albizia adianthifolia</i> - Mtangatanga		Timber, soil fertility
<i>Azelia quanzensis</i> - Msambamfumu		
<i>Fidherbia albida</i> - msangu	Scattered planting in crop fields	Soil fertility improvement
Bamboos	Boundary planting, gully reclamation, planting on land unsuitable for crops	Construction materials, weaving baskets and chairs etc.

Food and fuel do not always have to compete for land. By growing crops which have thick woody stems, you can increase the amount of food you have for your family, increase your income through sale of excess food, and have a ready supply of wood fuel which can be effectively and efficiently burned on an improved cook stove like the Chitetezo Mbaula. One of the benefits of the Chitetezo Mbaula is that it does not have to be fuelled only with firewood, other woody material can also be used.



Some food crops such as pigeonpeas can fertilise the soil, the stalks can be used as fuel and extra peas can be sold as a cash crop.

## **CHITETezo MBAULA DRAFT GUIDELINES**

### **CHAPTER SIX – IMPROVED COOK STOVES AND GENDER**

#### **CONTENTS**

<b>6.1 - Objectives .....</b>	<b>63</b>
<b>6.2 - Introduction .....</b>	<b>64</b>
<b>6.3 – Impact of Chitetezo Mbaula on women .....</b>	<b>65</b>
<b>6.4 - Chitetezo Mbaula – a business for women .....</b>	<b>66</b>
<b>6.5 – Chitetezo Mbaula and children and woman’s health.....</b>	<b>67</b>

#### **6.1 - Objectives**

This chapter serves to highlight how the Chitetezo Mbaula is likely to benefit women more than anybody else from having; less smoke while cooking, less time and effort collecting or purchasing firewood and by also learning new practices and skills that help save firewood and make the kitchen more efficient. The stove making and selling business has proved to be dominated by women as they are the best supporters of positive change and can share their experiences from using the Chitetezo Mbaula and how it has changed their lives.

## 6.2 - Introduction

Traditionally in Malawi, the kitchen is known to be a “women’s place”. A woman is expected to do all the cooking and also cleaning the home and taking care of children. The kitchen is seen as one of the women’s main workplaces in the home, but the one with the worst indoor environment, especially in rural areas. These kitchens usually have a lot of air pollution from smoke; are very hot and humid; and in general may be a messy and dirty place.

Firewood is the main source of fuel for cooking, which is usually done on three stone fires that are very inefficient, smoky and use up a lot of firewood. Women often spend a lot of time walking long distances to dangerous and far-off areas, a long way away from their homes to collect water and wood fuel, which increases their exposure to sexual and gender-based violence, and reduces the amount of time for education, employment, childcare, and other more economically productive activities.

Since women are generally in charge of cooking their families’ meals, they also inhale more smoke from unhealthy cook stoves. Smoke inhalation from cooking over an open fire kills more than a million and a half adults and children every year. Not only that, women walk long distance to find wood for cooking, often carrying very heavy loads under difficult conditions, and also cutting down trees in areas that already suffer from tree shortages.

However, changing to using improved cook stoves can help to improve the safety and well being of women and children. This will also reduce the time and distance women and children have to go to find fuel and give them chances to use their time to do other things. Women can also start small businesses to promote use of improved cook stoves to a lot of households.



**Scarcity of firewood puts greater pressure on women.**



## 6.3 – Impact of Chitetezo Mbaula on women

### Reducing women's time input

Using the Chitetezo Mbaula can help to reduce women's time spent collecting firewood and also time cooking and cleaning. As less firewood is used less time is spent gathering or buying firewood. When a Chitetezo Mbaula is used properly and suggested improved firewood and kitchen practices are used, firewood use can be 60% to 80% lower than that of a three-stone fire, resulting in a similar amount of savings in time and effort in collecting or buying firewood. Also less time is spent cooking, as the Chitetezo Mbaula cooks faster. Many women also say that they spend less time cleaning pots, because the Chitetezo Mbaula is cleaner than the three stone fires.

### Improved health and sanitation

Through reduced smoke production, Chitetezo Mbaula makes a significant contribution to improving kitchen environments. Because firewood burns better and less wood is used, the Chitetezo Mbaula produces less smoke. Less smoke means better health for the cook and the rest of the family, especially the women and children who spend more time in the kitchen. This means less time being sick or visiting the clinic and this will also save money and allows children to spend more time in school.

### Empowering women

Women get many benefits from their participation in the production, marketing and sales of improved stoves which give them economic power. Spaces made available for discussions at group level, provides women an opportunity to learn to express themselves and communicate their needs which helps women to be more independent and also realise that the future is in their hands.



Smoke may compromise the taste and quality of food and can affect all family members.

## 6.4 - Chitetezo Mbaula – a business for women

Chitetezo Mbaula is made from clay, sand and then sold at a village level directly by the production groups or through village based stove promoters or retailers. Experience has shown that the majority of production group members and stove promoters are women. This is not surprising, as women more than anybody else understand and appreciate the importance of using improved cook stoves. Women best understand the benefits of the Chitetezo Mbaula and they are the best people to demonstrate and sell these benefits.

Stove businesses are a good source of additional income, helping to expand and improve household livelihoods. Most of the women in stove business have learned new skills of producing, firing and selling Chitetezo Mbaulas, often from their peers from other villages. This is a form of empowering women and of creating opportunities for experiences to be shared and for enabling discussion on how to overcome various barriers that come up. Women that succeed at making or selling stoves can afford to buy more things, such as farm inputs or livestock that enable them to improve their lives. It is also possible to start new businesses based on the benefits received from stove businesses.

Empowering women can have many benefits for the whole household or family. Women tend to re-invest their income back into their family and communities more than men. This can bring about other benefits including better access to education for their children, as they are able to pay school fees.



Women can be better at making decisions for the family on how money is spent.

## 6.5 – Chitetezo Mbaula and children and woman’s health

Infants and children under 5 are the most in danger of respiratory infections and pneumonia. It is important to keep children away from smoke during cooking periods if there is a safer place to look after them. If not improved cook stoves, such as the Chitetezo Mbaula, are healthier than three stone fires because they produce less smoke. Babies that breastfeed exclusively for at least 6 months are less prone to getting pneumonia during their first 2 years. Immunised children have a lower risk of catching pneumonia.

Young girls, like their mothers and grandmothers, benefit greatly from improved cook stoves such as the Chitetezo Mbaula. By spending less time on collecting wood girls have more time to concentrate on their education and do their homework. By relieving girls of the burden of collecting wood can also increase their social development through playing with friends and the physical exercise promotes healthy child development. Children also learn to make decisions when playing with friends and improve creative development and expression. Girls’ health can also improve due to less exposure to smoke. From a security point of view, there is less exposure to dangerous and far-off areas in search of firewood.

Pregnant women particularly benefit from improved cook stoves such as the Chitetezo Mbaula. Again less exposure to smoke is particularly helpful to reduce respiratory infections during pregnancy. Some studies have linked exposure to smoke to bad pregnancy outcomes. Pregnant women avoiding carrying heavy loads, such as during firewood collection may avoid prolapse during pregnancy. Reduced exposure of the developing embryo to harmful pollutants may avoid low birth weight as well as stillbirth.



Cleaner air can help children to spend more time on school.

## CHITETEZO MBAULA DRAFT GUIDELINES

### CHAPTER SEVEN – IMPROVED COOK STOVES AND CLIMATE CHANGE

#### CONTENTS

7.1 - Objectives .....	68
7.2 - Introduction .....	69
7.3 – Local impacts of climate change .....	70
7.4 - Coping with climate change .....	71
7.5 – Cleaner development paths and carbon credits .....	72
7.6 – Monitoring for carbon credits .....	73

#### 7.1 - Objectives

This chapter shows how the use of the Chitetezo Mbaula has a very important role to play in addressing climate change – not only to reduce emissions of greenhouse gases which influence climate change but also to help rural households that depend on firewood as their main fuel sources to be healthier, stronger and better able to cope with the effects of climate change. A brief explanation is also given on how carbon credits that promote cleaner development ways can be used to help promote the use of improved cook stoves such as the Chitetezo Mbaula.

## 7.2 - Introduction

The global climate or the environment in which we live is changing. The last decade of the 20th Century and the beginning of the 21st have been the warmest period since records began. The major contributing factor is that human activities are adding more greenhouse gases to the atmosphere than before and the heat from the sun becomes trapped.

Elderly people in the village can relate their experiences to how the climate is changing, how it used to be cooler, how the rains were more predictable and how there were not so many storms or dry periods. The changes greatly affect food availability for Southern Africa. Higher regional temperatures mean that growing seasons are shifting and rains are becoming more unpredictable.

We need to find the best ways to adapt and survive the unavoidable changes in climate. We have to plan as communities to promote integrated resource management. Communities need to make their own plans so that they take action and become more knowledgeable on how best to adapt. We need to act quickly.

As we adapt to new realities and plan for our future there are opportunities for all of us to choose cleaner development ways. These are climate friendly development ways where we chose to adopt new ways of doing things that result in less greenhouse gases in the atmosphere. One such option is to change to cleaner energy sources. We can do this by choosing to use improved cook stoves, such as the Chitetezo Mbaula, and also by adopting improved kitchen practices that conserve energy, preserve nutrients and make our fuel last longer.

To help and encourage the transition to cleaner development practices there are financial incentives available internationally for projects that clearly demonstrate how they promote cleaner development ways and result in less pollution. The more developed countries, which are the biggest polluters, pay for these financial incentives to individuals or organisations that cause the reduction of greenhouse gases in the atmosphere. These incentives are called 'Carbon Credits'. Correct use of Chitetezo Mbaula burns less firewood and gives off less smoke emissions into the atmosphere, so Carbon Credits can be generated. The money raised can bring the benefits of cleaner energy to more people.



### 7.3 – Local impacts of climate change

Malawi is an agriculture based country and compared to other countries it is not industrialised and is therefore not a major polluter. Despite having contributed to global climate change in a very small way, Malawi is one of the countries that are affected most by the effects of a changing global climate. Climate effects include, but are not limited to (1) less predictable rainfall patterns; (2) increase in temperature: It is believed that an increase in global temperatures by 2 degrees Celsius would mean an increase in Southern African temperatures by 4 degree Celsius; (3) increased occurrence of extreme weather events such as droughts and floods; (4) decreased or varying river flow; (5) increased occurrence of wildfires and (6) more frequent landslides in mountainous areas.

These climate effects are making people's lives in Malawi more difficult as most people live off rain-fed agriculture so if rainfall becomes less predictable so too do people's livelihoods. There may be associated negative results to the farming system such as changes in the prevalence of weeds and other unwanted pests. Food production may become more erratic, affecting food prices and availability.

Changes in temperature and rainfall can cause insects such as mosquitoes to be active for longer periods, which may increase health risks such as increasing the likelihood of malaria transmission. Health effects could be worst for the very young, very old, persons already living with illness, and those with little income.

Warmer temperatures and precipitation changes will likely affect flora and fauna. The range and distribution of many species will change, and some species may face extinction. Loss of biodiversity may mean less species for food, fibre, fuel, shelter, medicine, wildlife trade, and other beneficial services provided by nature.

In a warming climate, extreme events like floods and droughts are likely to become more frequent. More frequent floods and droughts will affect water quality and availability. Droughts may result in water shortages and restrictions on water usage, more intensive rainfall can lead to floods. Loss of water resources would also have negative impacts on Malawi's fisheries sector. Such additional hardships could lead to "climate refugees" and conflicts over natural resource management.

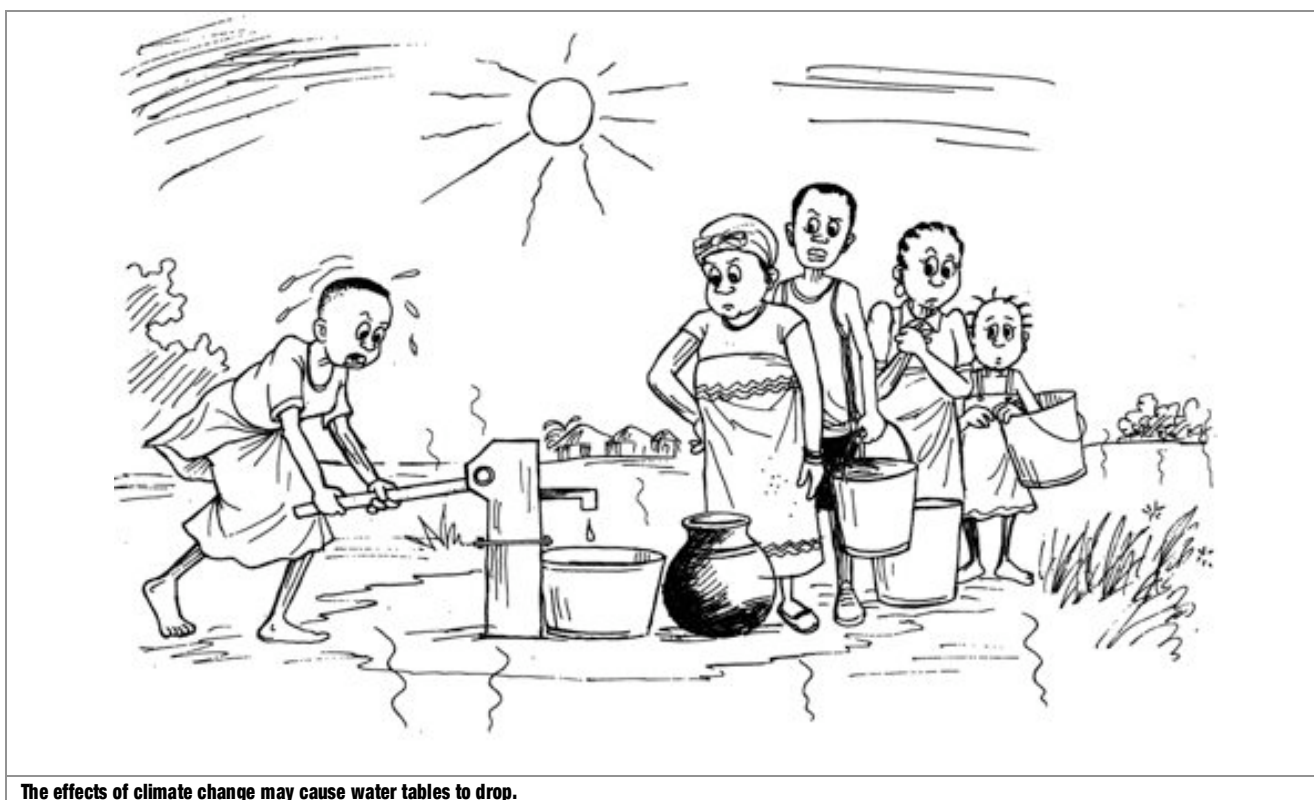

## 7.4 - Coping with climate change

Even if we could stop global greenhouse gas emissions and pollution today, we would still have to contend with the effects of the greenhouse gases currently in our atmosphere for many years to come. Changes in our climate may be of benefit to some countries or regions, but for Malawi the expected changes make people's lives more difficult. Therefore, we must find ways to reduce and adapt to the expected effects of climate change. We need to cope with the changes that are already happening and plan wisely for those that are coming.

At a household or individual farm level, farmers can adapt to changing circumstances by planting different crops in different seasons and by changing the timing of planting to adapt to changing growing conditions; changing cropping mix and forest species that are better suited to the changing climatic conditions; breeding new plant species and crops that are less vulnerable to unpredictable weather patterns; controlling insect outbreaks; and by growing a diversity of crops and fruits in addition to cash crops. Conservation agriculture and smart agricultural practices are becoming more beneficial approach to farming by using crop residues (stems, stalks, non-edible leaves) as organic soil cover and by inter-planting/intercropping staples with nitrogen fixing plants such as peas and beans, farmers can return nutrients to the soil and maintain sufficient soil moisture.

At a community level it is becoming more important to set up disaster risk reduction plans, for example, promoting fire control practices in the event of increased fire risk due to temperature increases, or emergency responses for floods due to more intense storms. Planning activities may not be limited to individual villages or TAs and may require for integrated development plans. For example, the planting trees along the river banks to protect against property and crop damage and to lessen the effects of flooding is likely to require partnership between various stakeholders from various Districts. Grain storage and emergency feeding centres may be set up for times when food production may fall below requirements;

Use of the Chitetezo Mbaula may be part of adapting to new conditions as it strengthens the ability of households to cope better and may also contributes to integrated village or District plans to manage natural resources.



**Crop residues can help our soils by improving water retention and fertility and can be used as a sustainable source of fuel for Chitetezo Mbaulas.**

## 7.5 – Cleaner development paths and carbon credits

The main causes of greenhouse gas emissions at a global level are from heavy industries, from the burning of fossil fuels (oil, gas and coal) to generate heat and energy for production, buildings and transport; from waste management and from changes in how we use our land that lead to land degradation and deforestation that release natural gases into the atmosphere. Cleaner development ways leave a smaller environmental footprint and lessen climate change and include the use of renewable energies that do not rely on fossil fuels; the use of renewable fuels such as wood that is harvested sustainably; the reduction, recycling and reuse of waste and the reversal of land degradation and deforestation.

A developing country like Malawi is not obliged to reduce its emission of greenhouse gases, but it may chose a cleaner development path for various reasons. By reducing reliance on imported and increasingly expensive fossil fuels can make the economy more resilient. By sustainably managing forests and lands they can be more productive. By increasing the hydroelectric capacity in Malawi and by promoting other forms of renewable electricity generation from solar, wind, biomass and geothermal Malawi can meet it s energy needs and sell electricity to its neighbours. By increasing the use of locally produced sugarcane ethanol as a liquid fuel, Malawi can import less. By using a Chitetezo Mbaula to make households healthier and stronger.

Industrialised countries cause most of the pollution and now have to pay if they make too much greenhouse gases. They have to buy 'Carbon Credits' as a way to offset their high emissions. By burning less wood, measuring this properly and registering it, Carbon Credits can be made in Malawi. Using your Chitetezo Mbaula properly means less wood is burned and Carbon Credits are made. The Carbon Credits can be transferred from the household that is using the improved cook stoves to help to finance the promotion of improved cook stoves and cleaner development paths. The credits are sold to industrialised countries to raise money for the project, to make the air cleaner and to promote development that lasts.

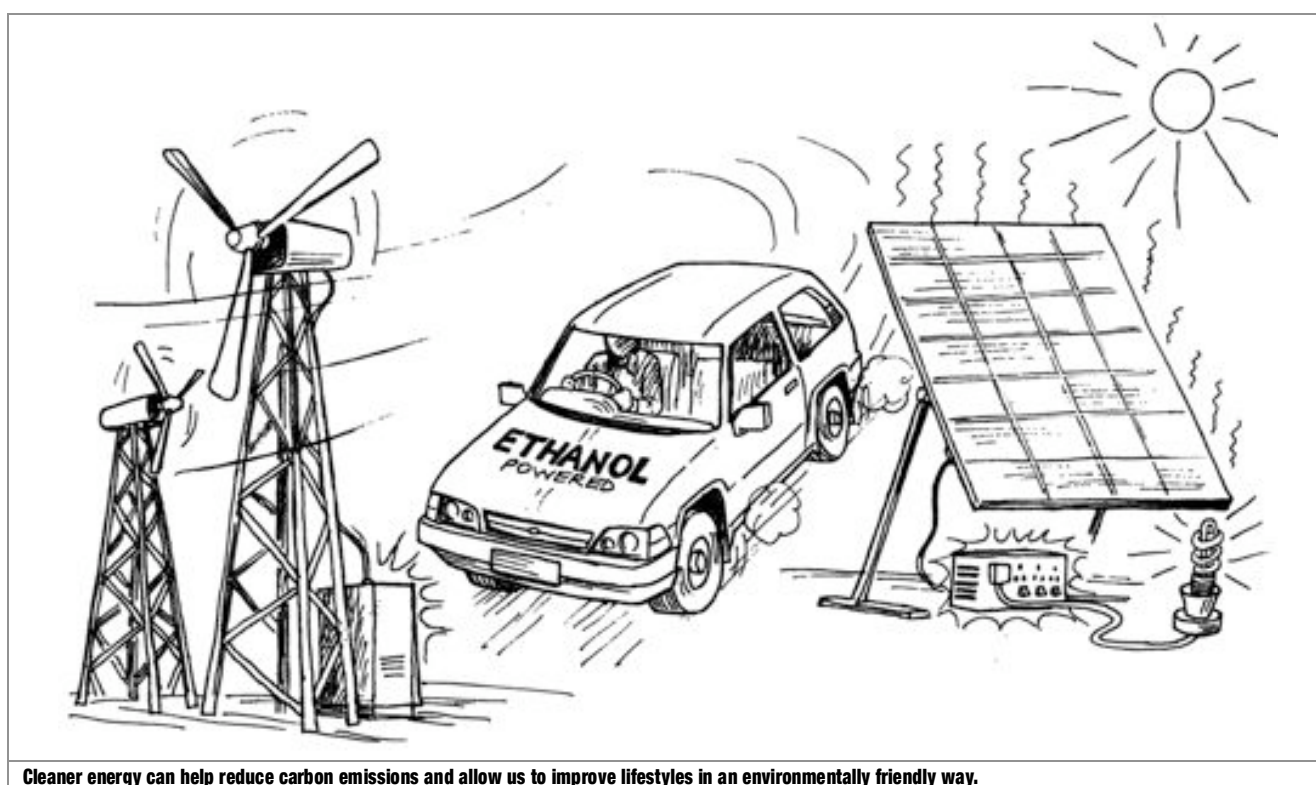

Cleaner energy can help reduce carbon emissions and allow us to improve lifestyles in an environmentally friendly way.



## 7.6 – Monitoring for carbon credits

Before rolling-out improved cook stoves it is important to assess the baseline scenario. Later on you do follow-ups to understand the before and after situation. For the Chitetezo Mbaula a comprehensive baseline and follow-up survey was conducted in Balaka in 2009. This is the basis of fuel-savings and emission reductions estimates for DISCOVER project and will be revised in 2015.

For internal quality control it is important that each stove is assigned a reference number that is traceable to its production batch. A key ongoing monitoring activity is to track sales information which includes: date of sale, user name of end-user, phone (if available), village, GVH, SAT / TA, date of stove demo, and informed consent to transfer emission reductions rights to the project and for end-user to give consent to be monitored periodically.

For surveys and tests customers are randomly sampled. Monitoring surveys are carried out every 6 months to find out more about if the customers are using their stoves, what fuel they are using, for what purposes and if there are any seasonal variations. Usage surveys are conducted once a year. To show how many users on the database have “dropped-off” or are no longer using the stoves, based on stoves of different ages.

Fuel Test Updates are conducted every 2 years, with the next fuel test in 2011. To account for changes in the performance of the stoves over time as project stoves age and new customers are added. May be through a water boiling test or a kitchen performance test depending on feedback from the Gold Standard.

Sustainable development indicators should also be updated once a year. Indicators include livelihood of the poor, number of stove producers / retailers with improved income generation opportunities; number of producers & stove promoters trained in new skills; air quality based on concentrations of smoke during cooking time; monitoring the source location of clay, the clay site type, the mining type and the planned environmental management.

Household stoves that claim carbon credits are periodically verified by outside auditors. It is very important to be able to trace each stove so it is good if end-users are interested in keeping in touch with you. Encourage more than one stove per household just in case one stove breaks. Make sure to avoid counting the same stove twice as this is a crime in the carbon market and could result in the project being disqualified to generate verified emission reductions.



Surveys and tests are very important activities to demonstrate changes in wood consumption and associated emissions.



## Further Information

Abbott, V. Heyting, C. Akinyi, R. *How to make an Upesi Stove – Guidelines for small businesses*, Intermediate Technology Kenya, 1995.

Abbott, V. *Report on Stove Training*. IFSP: Mulanje, Malawi, 2000.

Agumba, M. and Abbott, V. *How to build, use and maintain a better bonfire kiln*, Intermediate technology Kenya, 1996.

Barnes, D. F., Openshaw, K., Smith, K. R., and van der Plas, R., *What makes people cook with improved biomass stoves?* World Bank Technical Paper Number 242, Energy Series, Washington D.C., 1994.

Bunderson, W.T., Jere, Z. D., Hayes, I. M. and Phombeya, H. S. K. *Landcare practices in Malawi*, Malawi Agroforestry Extension Project, Lilongwe, 2002.

IFSP *Cookery Book for the Energy Saving Stoves Published by the Food Processing Sector of the Integrated Food Security Programme*; 1<sup>st</sup> Edition by Gisela Hock, October 2000, 2<sup>nd</sup> Edition by Christa Roth, Mulanje, February 2003.

Imaya E, Kapondam'gaga P. *The Impact of HIV and AIDS on agriculture and rural livelihoods in Dedza District*, Malawi, 2003.

Messinger, C. and Roth, C., *Benefits of Chitetezo stoves*. Integrated Food Security Programme (IFSP) Mulanje, May 2004.

Messinger, C. and Roth, C.; *Household energy saving technologies (intervention 3)*, Programme for Biomass Energy Conservation in Southern Africa, October 2005.

Roth, C. *The role of energy for HIV mitigation*. Programme for Biomass Energy Conservation in Southern Africa, 2005.

Senefeld, S. *Nutrition and HIV/AIDS: A Compilation of Research Results Regarding Recommended Nutritional Inputs for People Living with HIV or AIDS* Catholic Relief Services, 2003.

Sileshi G, Akinnifesi FK, Ajayi OC, Chakeredza S, Kaonga M, Matakala P. Contribution of agroforestry to ecosystem services in the miombo eco-region of eastern and southern African. *African Journal of Environmental Science and Technology* 1(4): 068-080, 2007.

Westhoff, B. and Germann, D. *Stove Images: A Documentation of Improved and Traditional Stoves in Africa, Asia and Latin America* (Year)

WHO, *Fuel for Life – Household Energy and Health*, 2006.

### Websites:

Aprovecho Research Centre ([www.aprovecho.org/](http://www.aprovecho.org/))

Global Alliance for Clean Cookstoves (<http://cleancookstoves.org/>)

Health Canada (<http://www.hc-sc.gc.ca/fn-an/nutrition/prenatal/index-eng.php>)

HEDON Household Energy Network (<http://www.hedon.info/>)

Household Energy Program (GIZ / HERA) <http://www.gtz.de/en/themen/12941.htm>

Medscape (<http://www.medscape.com/viewarticle/572069>)

Partnership for Clean Indoor Air (<http://www.pciaonline.org/>)

World Health Organisation (<http://www.who.int/mediacentre/factsheets/fs292/en/>)

**Videos:**

Barbee, J. Creating a Climate for Change, Johannesburg, 2012.

Gates, M. What non-profits can learn from Coca-Cola, 2010.

Wood Energy – Africa’s Green Energy Future, GTZ, HERA – poverty –oriented basic energy services, 2010.